

PRO SERIES INSTALLATION MANUAL

READ ME
Designed for
both pros and
beginners!

Watch the full
Pro Series install
video



SCAN ME



RPS | RURAL POWER SYSTEMS INC.
40250 Co Rd 27
Woodland, CA 95776

- CALL OR TEXT 530.240.3825
- [RPSsolarpumps.com/PRO](https://www.rpsolarpumps.com/PRO)
- support@ruralpowersystems.com

OUR PLEDGE TO YOU

Dear Customers,

In an effort to shape the way our company does business, our mission statement includes a series of pledges to you, our customers.

- ✔ **We pledge to give you the power!** Controlling your own ability to pump water out of the ground, whether in the field or at home, allows you to be more resilient. Freeing your water source from the grid is a major step towards self-sufficiency. You just bring the DIY spirit! Our engineers will be on the other end to offer specialized knowledge and answer questions, so you can install our solar pumps confidently and gain total control over your water supply.

- ✔ **We pledge to be a company our grandfathers would have trusted.** The all-too-common practice of outsourcing customer support after the sale is one we wholeheartedly oppose. We are an American, family-run company and our USA engineers, who will support you before and after the sale, are the best in the industry. We gain most of our business from word-of-mouth as a result of treating customers with respect and standing by our products.

- ✔ **No Pressure. Ever.** Our sales team is not on commission—we think this is important. Their role is to match you with the right pump for your well. If we don't have a pump that will suit your needs, we'll help you find a solution elsewhere. Our job is to help get you water, not sell you something that isn't a good fit.

- ✔ **We pledge to bring you reliable water!** All manufactured products have occasional issues and we can't claim to be perfect. Well water varies in pH, iron level, and sand content. With that said, we are extremely proud of our 100% track record in getting our customers water. That's right, every single one of our customers is now successfully pumping water with an RPS system. This starts with making sure we supply you with the right pump for your land, and if issues do arise, we will immediately provide technical support and replacement parts so you can get up and pumping again as quickly as possible.

Sincerely,
The RPS Family

TABLE OF CONTENTS

System Components.....	4
Things You Will Need.....	5
System Overview.....	6
Controller Overview.....	7
Mounting Solar Panels.....	9
Wiring Solar Panels.....	10
5HP Wiring Diagram.....	11
Using Existing Panels.....	12
System Grounding.....	14
Well Pump Assembly.....	15
Plumbing & Safety Line.....	18
Well Pump Plumbing.....	19
Dewatering Plumbing.....	23
GB Booster Plumbing.....	24
Surface Irrigation Plumbing.....	25
Priming Surface Pumps.....	26
Pro Controller Wiring.....	27
Connecting AC power.....	32
Dewatering Wiring.....	34
Surface Pump Wiring.....	34
Bucket Test.....	37
CHECKLIST: Ready To Lower Your Pump?.....	38
Shut Off Sensor.....	39
Indicator Lights.....	41
System Keypad.....	42
How Pressure Switches Work.....	43
Winterizing.....	44
Warranty.....	45
Support	46

This manual will...

- ✔ Answer your questions before you have them!
- ✔ Enable you to have the tools and equipment you need on the day of installation to help everything proceed quickly and enjoyably
- ✔ Ensure that you install safely and avoid any damage to your equipment
- ✔ Make sure you don't miss anything with highlighted KEY STEPS sections
- ✔ Give you a resource for troubleshooting in the field, even without cell reception

As always, we are here to help if you still have questions after working through the manual:
Support@ruralpowersystems.com

Text Or Call
530.240.3825



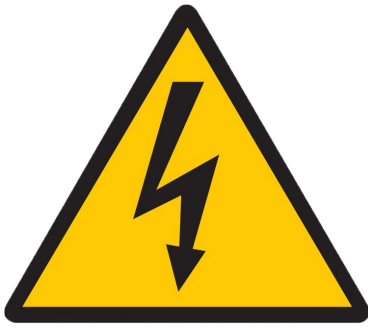

Warning: Risk of Electric Shock

Solar panels and batteries can produce a significant amount of energy, which can cause electric shock. Please exercise caution when installing your solar well pump and follow the step-by-step instructions in this manual for your safety.

Whenever you're working with wiring or connections, make sure:

- the controller is set to OFF
- solar panels are covered
- there are no exposed wires

Be sure to ground the system for safety and to prevent damage to equipment.

Remember, safety first! RPS is not liable for damage or injuries that result from improper installation technique. If you're unsure about the safety aspects of any step in this manual, please consult an RPS Engineer.

SYSTEM COMPONENTS

- 1. PUMP** — Your system will either come with one of our Well Pumps, Surface Pumps, or Dewatering pumps. In the case of our well pumps you will have a motor and a pump end that will need to be assembled.
- 2. PUMP CONTROLLER** — This large sturdy controller is the brains of the system. Arrives pre-programmed for the specific HP your pump and motor and will adjust the speed of the pump's motor based on available power from the sun. The pump controller is waterproof but protecting it from direct sun and weather is still encouraged. We suggest mounting underneath the shade of the solar panel array.
- 3. FLOAT SWITCH** — This can be used in a storage tank to tell the controller to stop pumping when the tank is full. Wires can be extended with any two strand wire. Wire gauge is not important, as they are signal wires but common wire gauges are between 16 to 24 gauge.
- 4. HOSE BARB AND HOSE CLAMPS** — Submersible Well Pumps Kits Only. The corrosion-resistant stainless steel fitting allows for the connection to poly pipe. Use minimum of 160 psi poly for up to 300' and 250 psi for lengths up to 500'. Mos recommend rigid plumbing after that.
- 5. SOLAR CONNECTOR WIRES** — 2 wires with MC4s. These will connect your panels to your DC Disconnect. There are 2x 20 foot lengths of solar extension cable to connect the panels.
- 6. DC DISCONNECT SWITCH** — An instant shut off switch rated for the DC power. This switch allows the power from your solar array to be shut off from your controller. NOTE: in some larger systems you may receive multiple.

PRO SERIES ACCESSORY KIT— Every Pro Series kit will come with most of the accessories you need. In your accessory kit your will find: 7) Mounting & Grounding Kit 8) Pump Splice Kit 9) Tank Sensor Splice Kit 10) Electrical Tape & Teflon Tape 11) Keypad and wire for advanced use only 12) Plug connector for Pump Wires & Optional AC Input 13) Tank Sensor Plug & Pigtail

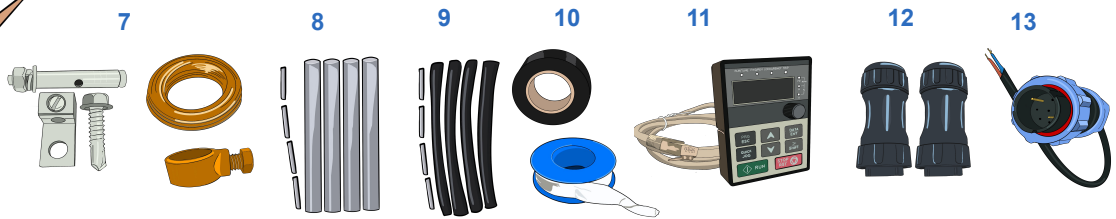
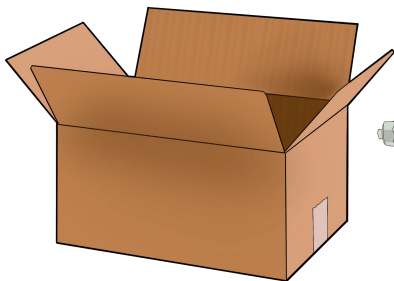
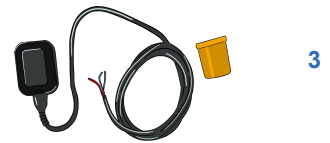
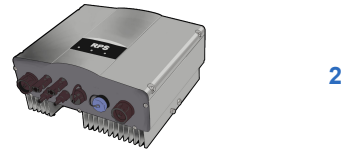
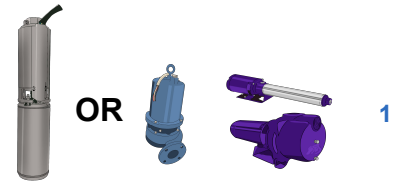

THINGS YOU WILL NEED

Necessary equipment

- **Pump wire extension:** Use 10 gauge 4-strand wire (4 conductors, often called 3+Ground) to extend the pump wire to your desired depth. More details are provided in the next section.
- **Tank sensor wire extension:** To extend the available length of your sensor wire between tank and controller. Found in the Communications / Home Security section of your local hardware store.
- **Drop pipe:** Black poly pipe is most common and easiest to work with; this attaches to your pump end. PVC and steel pipe may also be used. More details are provided in the next section.
- **Polypropylene rope:** Cut to desired depth and attach to the pump as a safety line. The drop pipe will hold the pump, but the rope will support the pump in case the drop pipe breaks or is damaged.
- **Grounding rod:** To ground your controller and panels. Clamp and 6' of copper wire



Recommended equipment

- Something to seal the top of your well casing or well seal.
- Solar panel mount: RPS offers 8-panel adjustable top-of-pole mount and Scalable Ground Mount kits that are compatible with 4.5"OD Schedule 40 Steel Pipe (for the 8-panel) the Scalable Ground Mount that mounts on a 2" substructure for up to 40+ panels (rpssolarpumps.com/mounting). This pipe and cement are not included as it is too bulky to ship with kits. Alternatively, use any mounting design of your choice—creativity is encouraged!

Tools

Here's a list of the tools you'll want to have on hand during installation:

- Wire stripper/crimper
- Screwdrivers (flat and Phillips head)
- Electrical tape (for attaching wire to drop pipe)
- Teflon tape for tight thread connections (recommended)
- Two adjustable wrenches
- Heat gun or butane torch for heat-shrink sleeves
- Multimeter (highly recommended)
- Large bucket or barrel for testing the system

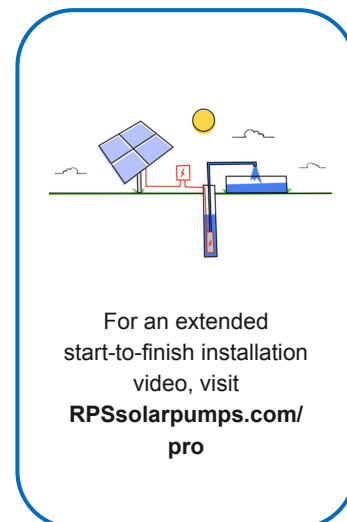

For an extended start-to-finish installation video, visit RPSsolarpumps.com/pro

USER MANUAL

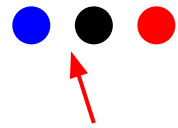

RPS Systems are designed for a wide range of pump styles and sizes. Some components are universal (like the Controller, Mounting, AC Input Wiring, Pump Wiring, Sensor Wiring) and some plumbing and wiring will be specific to your pump and system size. We'll indicate that throughout the user manual with colored dots in the top right corner.

PRO TIP: At the top of each page you will see one or more colored dots, each of these colors correlate with one of our products. **Well Pumps in blue,** **Dewatering Pumps in black,** and **Surface Pumps in red.**

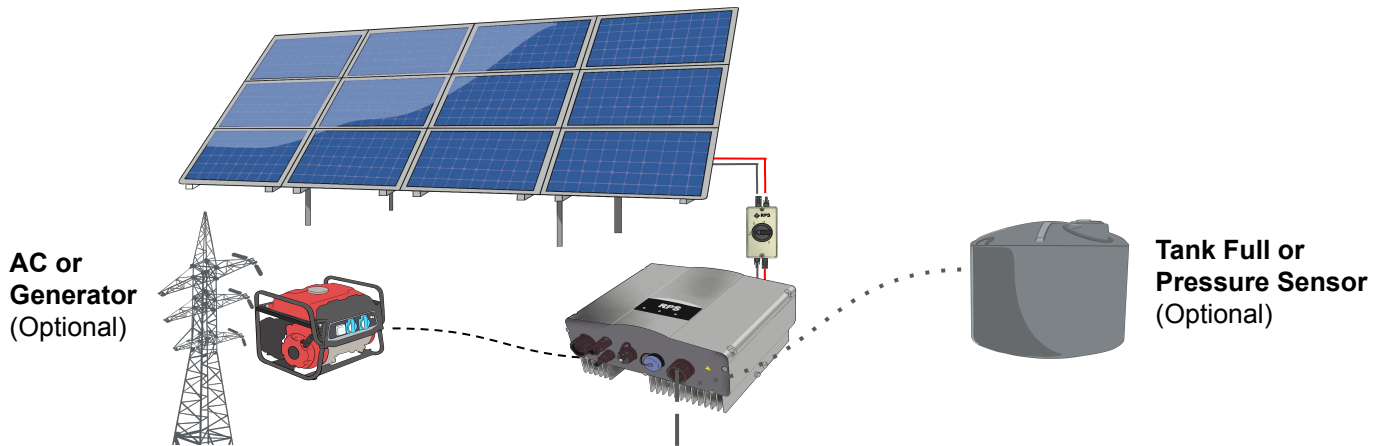

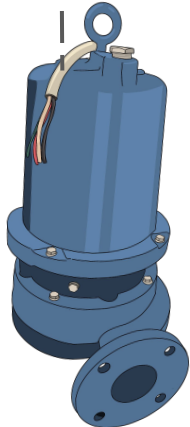
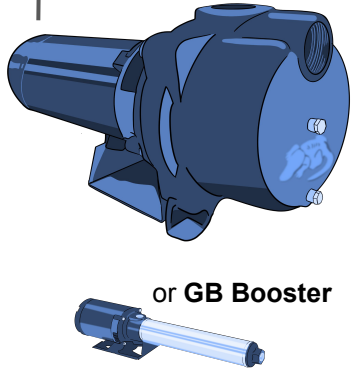
 <p>Well Pumps</p>	 <p>Dewatering Pumps</p>	 <p>Surface Pumps</p>
<p>1-¼ to 2” Outlet</p>	<p>2 to 3” Outlet</p>	<p>1-½” to 3” Outlet</p>



PUMP CONTROLLER OVERVIEW

The RPS Pro Series Controller is the brains of your setup. This highly intelligent apparatus is pre-programmed and will regulate the power coming from your panels to run your pump correctly. Each Pro Series controller is constructed of heavy duty metal and is water resistant. They weigh in at ~20 LBS and have the following inputs and outputs.

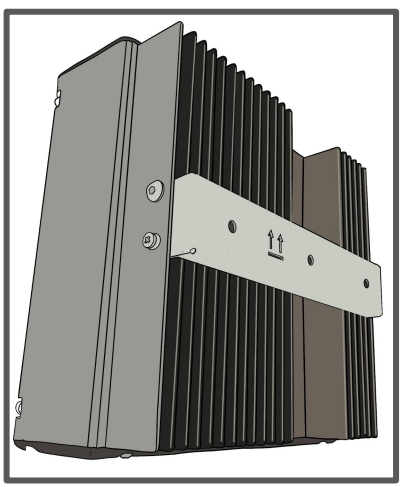
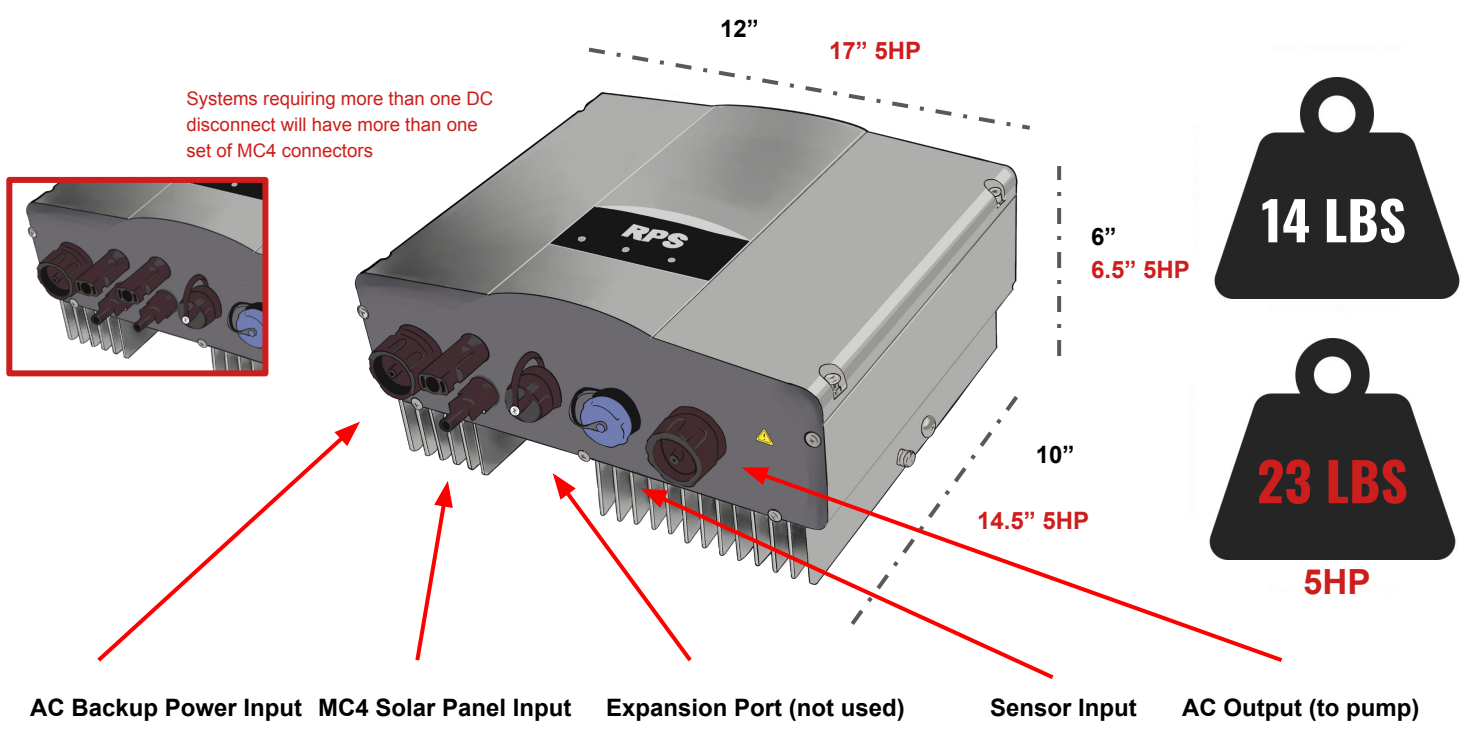

Mounting - The mounting plate on the backside of the controller can be detached, positioned and mounted in place with the included hardware. The controller hangs on the mounting plate with set screws on the side to prevent it from coming loose. The controller should be set as vertically as possible with at least 12 inches on all sides to provide ample room for cooling.

Simply **unfasten the screws on the side of the heat sync**, and remove the mounting plate, then **use the holes in the plate to fasten the plate** onto whatever you are mounting to. Then refasten the controller to the plate **by replacing the screws on the side of the heat sync**. The self-drilling screws are great for metal and wood posts.

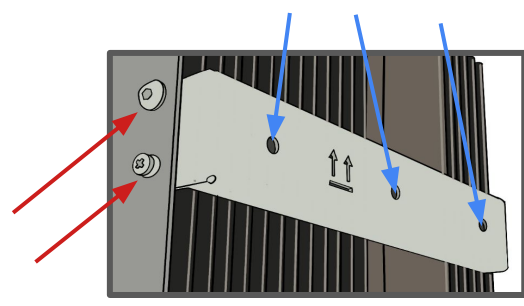

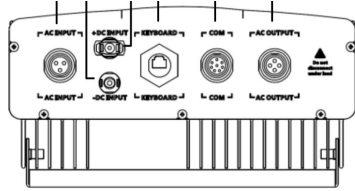
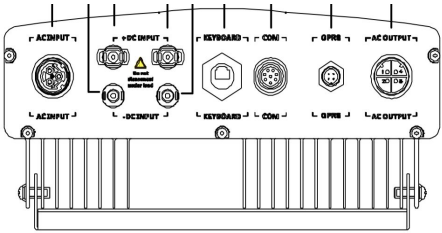

PUMP CONTROLLER Specifications

	RPS22PRO	RPS40PRO
Compatible Systems	Pro 500, 750, 1000, 1500, 2000, 3000 <i>(Well, Submersible, Irrigation, Effluent, and Sewage)</i>	Pro 5000, Pro 3000 1PH AC Conversion <i>(Lakemakers, Well, Submersible, Irrigation, Effluent, and Sewage)</i>
Solar Min Voltage	100VDC	200VDC
Solar Max Voltage Max Current DC	450VDC 12A DC	450VDC 24A DC
MC4 Connectors	1 set (1 male + 1 female)	2 sets (2 male + 2 female)
Power Range	800w - 3200w	3200w - 6400w
AC Input Compatible	220V Single Phase 60hz, 9-15A	220V Single Phase 60hz, 24-30A
Motor Compatibility	220V 3 Phase, 220V Single Phase (3 Wire only)	220V 3 Phase, 220V Single Phase (3 Wire only)
Minimum Generator Size	6kW min (varies based on waveform output quality)	10kW min (varies based on waveform output quality)
Temp. Range	-25 to 60°C, -13 °F to 140 °F	-25 to 60°C, -13 °F to 140 °F
Weight	14lbs	23lbs
Height / Diameter	12 in x 10 in x 6 in 300mm x 255mm x 137mm 	17 in x 14.5 in x 6.5 in 410mm x 360mm x 154mm 





MOUNTING YOUR SOLAR PANELS

Solar panels should be mounted on a secure structure, ground mount or top of pole mount. Several ideas can be found at RPSsolarpumps.com/mounting

Panels should face true South and at an angle appropriate for your latitude. If you are mounting your panels on an already built structure, try to get as close to the correct angle as possible.

Ensure there are no shadows or other obstructions on the solar panels. While shadowing a small corner of a single panel may not seem like a big deal, since the panels are connected in series, a small shadow can limit the power output from all other panels connected in series! This means a small shadow on a single panel could reduce system power by hundreds of watts. Time to get out that chainsaw and trim some trees!

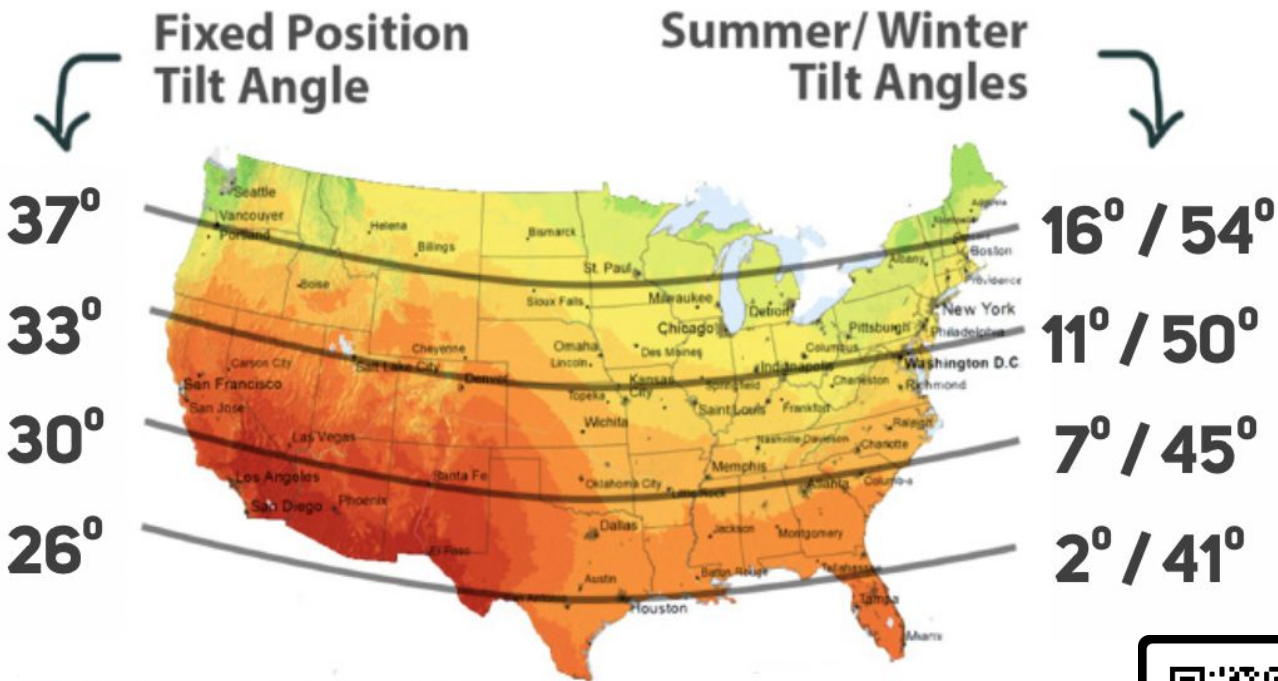
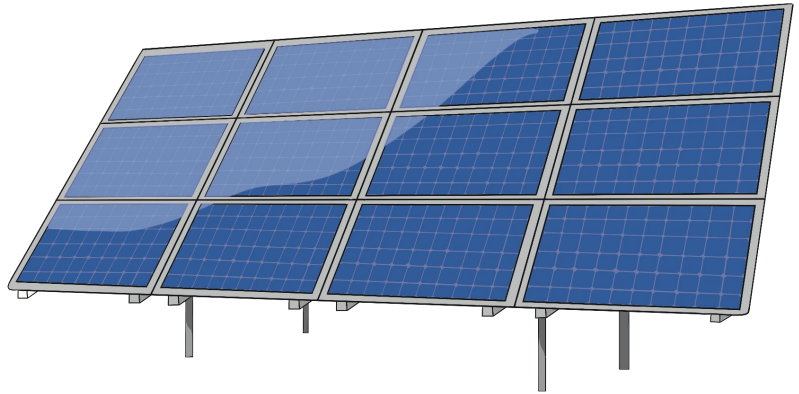

Scan here to use our tilt angle calculator tool!





WIRING YOUR SOLAR PANELS

Your panels will have two MC4 connectors on the back, male and female. You will use these connectors to connect each panel as shown, as well as to connect them to the DC disconnect shut off switch. After that, you will use the MC4 connectors from your DC Disconnect and connect into your controller. Below is a diagram for connecting the 1.5HP controller to the panels.

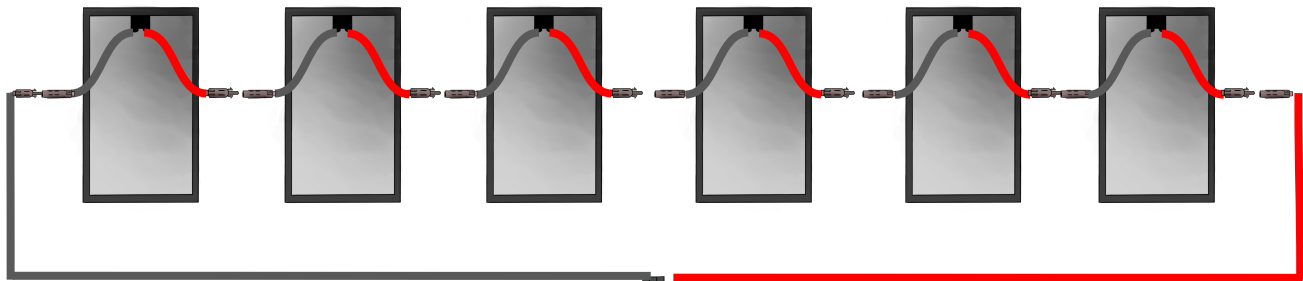
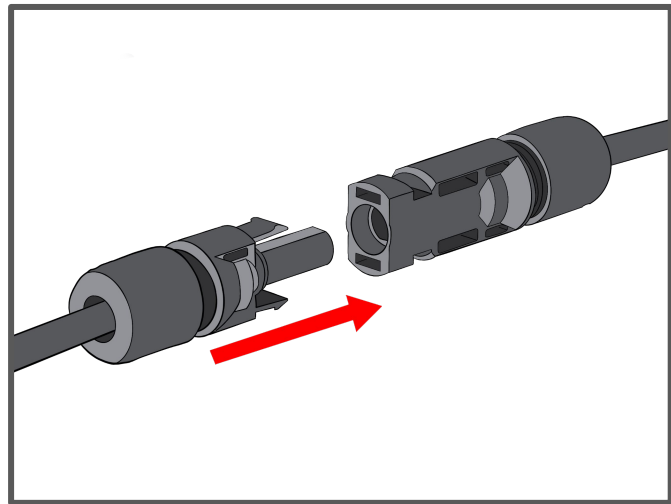

In general this is how you will wire each of your panels. In cases where you will need more than 10 panels you will need to add another DC Disconnect which goes into the second set of MC4 connectors in your controller.

PRO 1500 (1.5HP) Wiring Diagram

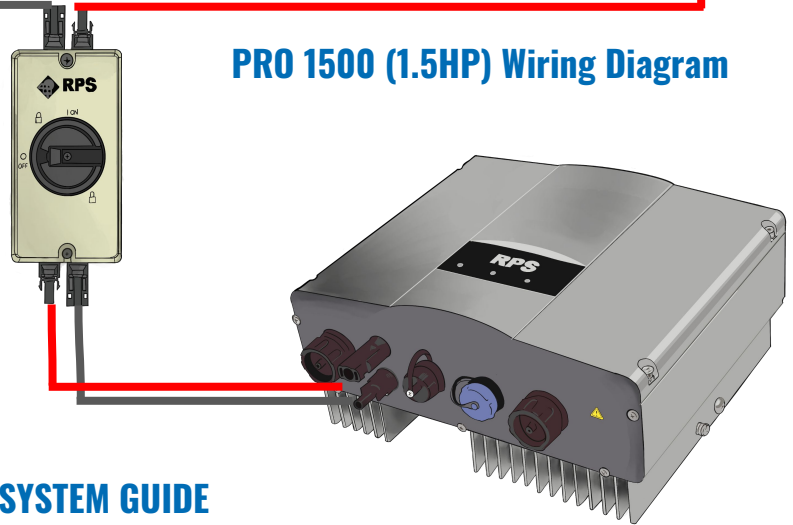

SOLAR PANEL SYSTEM GUIDE

SYSTEM	Pro 500 (1/2HP)	Pro 750 (3/4HP)	Pro 1000 (1HP)	Pro 1500 (1.5HP)	Pro 2000 (2HP)	Pro 3000 (3HP)	Pro 5000 (5HP)
100W	8	10	12				
Large				6	8	10	20

*WIRES SHOWN RED AND BLACK FOR ILLUSTRATION PURPOSES ONLY, ACTUAL WIRES WILL BE BLACK



CALL OR TEXT
530.240.3825



RPSOLARPUMPS.COM/PRO



SUPPORT@RURALPOWERSYSTEMS.COM



5 HP ONLY WIRING DIAGRAM

**USE ALL 4
CONNECTORS!**

Remember only use a maximum of 10 Solar Panels per pair of MC4 Connector Pairs

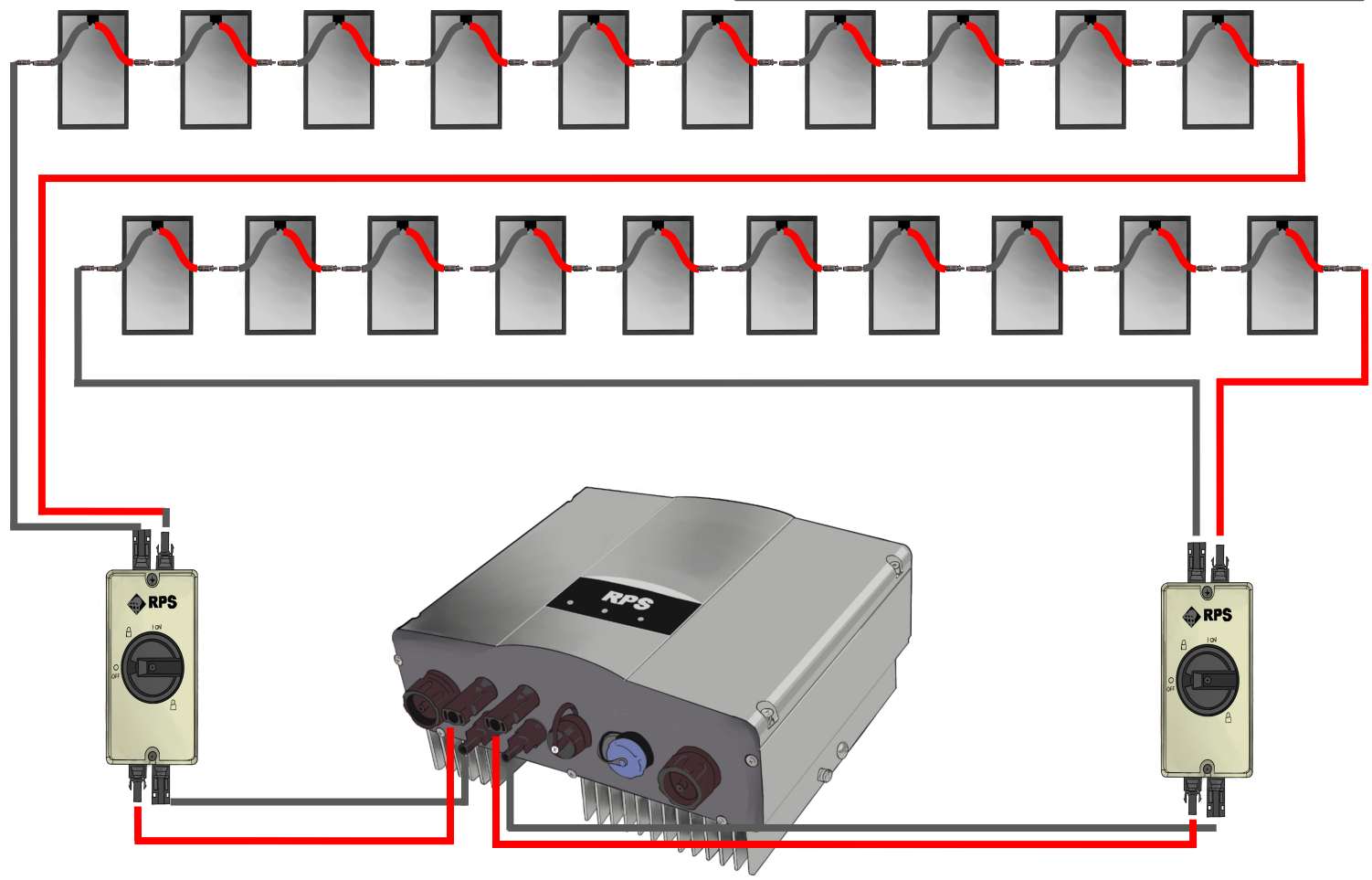
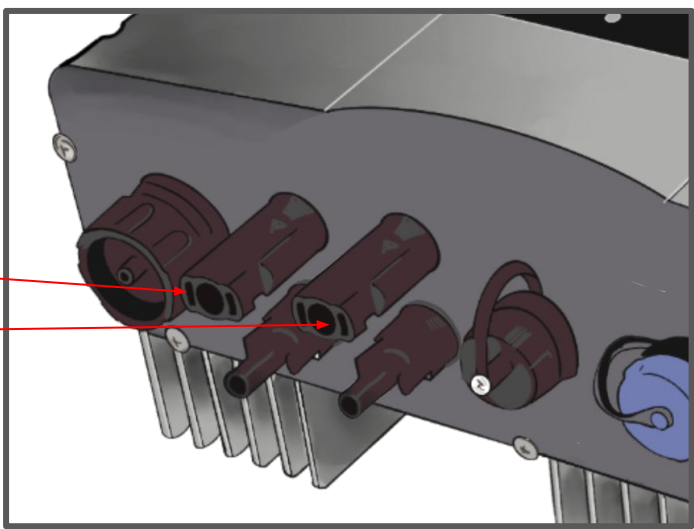

*WIRES SHOWN RED AND BLACK FOR ILLUSTRATION PURPOSES ONLY, ACTUAL WIRES WILL BE BLACK



USING EXISTING SOLAR PANELS

Are my existing solar panels compatible with RPS Solar Pumps?

Example: RPS 100w "12v Panel"



Solar Panel Sticker

(on reverse side under junction box)

Stats you'll need from the sticker..

Total Power (P_m , Watts)

Voltage Maximum Power (V_{mp} , Volts DC)

Voltage Open-Circuit (V_{oc} , Volts DC)

Optional stats:

Current Maximum Power (I_{mp} , in Amps)

Short-Circuit Current (I_{oc} , in Amps)

RPS PRO SERIES REQUIREMENTS

Min Solar Array Voltage	120v DC
Max Solar Array Voltage	360 V_{mp} 410 V_{oc}
Optimal Solar Array Voltage	260-320 V_{mp}
Examples Arrays	<i>Examples</i> 16x 100w 12v in series (288 V_{mp}) 10x 290w 24v in series (320 V_{mp})
Pump Wattage / Coefficient	Recommend 1.3x or more
Battery Bank Voltage	Not designed for batteries. Use backup of generator or grid 1 Ph 220v.

- 1) Stats from the sticker on the back of your solar panels **Total Power** (watts), **V_{mp}** (volts), **V_{oc}** (volts)
- 2) The total number of panels you have

Most Common Sizes	
"12V Panels"	"24V Panels"
Each panel is different but in general.. V_{mp} is 16v - 20v V_{oc} is ~20v - 23v	Each panel is different but in general.. V_{mp} is 30v to 37v V_{oc} is ~38v to 45v
Example RPS 100w Panels V_{mp} = 18.6v V_{oc} = 21.8v	Example RPS 290w Panels V_{mp} = 32.1v V_{oc} = 38.8v

$$P = I \times V \quad (\text{Power} = \text{Current} \times \text{Voltage})$$

1 horsepower (hp) = 745 watts



CALL OR TEXT
530.240.3825



RPSSOLARPUMPS.COM/PRO



SUPPORT@RURALPOWERSYSTEMS.COM

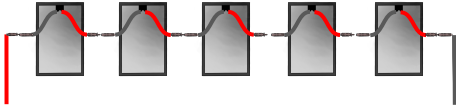
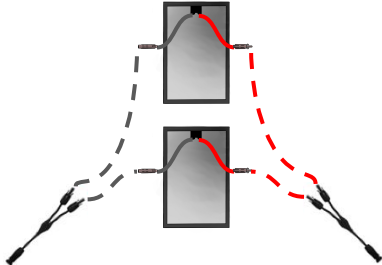
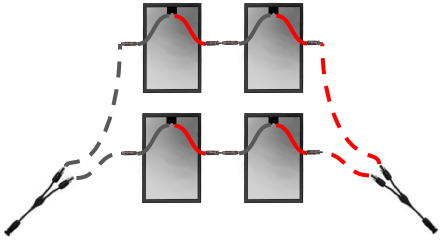

"Series"	"Parallel"	"Series / Parallel"
<p>Add voltage of every solar panel or battery in series, current stays the same. All the solar panels must be the same.</p> <p>$40v + 40v + 40v + 40v + 40v = 200v$</p> 	<p>Add current of every solar panel or battery in parallel, voltage stays the same. All the solar panels must be the same.</p> <p>$40v // 40v = 40v$</p> 	<p>Add voltage of every solar panel or battery in series, voltage stays the same when other sets connected in parallel.</p> <p>$40v + 40v // 40v + 40v = 80v$</p> 

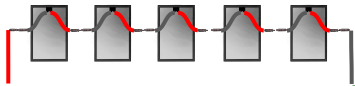
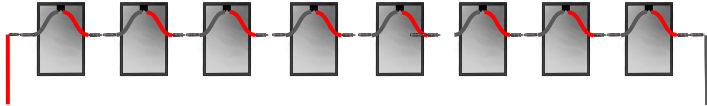
Rough Panel Specs	Pro Series Voc Max 410V (Ideally 400v)
<p>350 Watts 40 Vmp 45 Voc</p> <p>"72 Cell Panels"</p>	<p>Wired in Series</p>  <p>1) Check Voc: $45v * 4 < 410V$ ✓ 2) Check Vmp: $40v * 4 = 160Vmp > 120Vmp$ ✓ 3) Array Specs: $350w * 4 = 1400w @ 160Vmp$ Just over Pro 1000 performance. Probably not higher.</p> <p>MAX: Could add as many as 8 in series. $45 * 8 < 410V$</p>
<p>200 Watts 30 Vmp 36 Voc</p> <p>"60 Cell Panels"</p>	<p>Wired in Series</p>  <p>1) Check Voc: $36v * 8 < 410V$ ✓ 2) Check Vmp: $30v * 8 = 240Vmp > 120Vmp$ ✓ 3) Array Specs: $200w * 8 = 1600w @ 240Vmp$ Right around Pro 1500 performance. Maybe Pro 1000 with 8.</p> <p>MAX: Could add as many as 8 in series. $36 * 11 < 410V$</p>



SYSTEM GROUNDING

Controller grounding is required for system safety and helps protect your system. It is very important that you ground your controller. To do this locate the grounding screw (as noted by the symbol in image 1) on the side of your controller's heat sink. Take the grounding lug (located in your pro-series accessory bag) and secure it to your controller using the grounding screw.

Once the lug is secured to your controller loosen the crimping screw and insert your copper grounding wire, then tighten down the crimping screw.

A dedicated ground rod should be pounded into the ground as deep as possible to achieve a good ground.

Run your copper wire to a copper grounding rod, and then secure the bare copper wire using the bolt on the grounding clamp as shown in image 4.

Warning: Risk of Electric Shock

Solar panels and batteries can produce a significant amount of energy, which can cause electric shock. Please exercise caution when installing your solar well pump and follow the step-by-step instructions in this manual for your safety.

Whenever you're working with wiring or connections, make sure:

- the controller unhooked from the panels
- solar panels are covered
- there are no exposed wires

Be sure to ground the system for safety and to prevent damage to equipment.

Remember, safety first! RPS is not liable for damage or injuries that result from improper installation technique. If you're unsure about the safety aspects of any step in this manual, please consult an RPS Engineer.



1

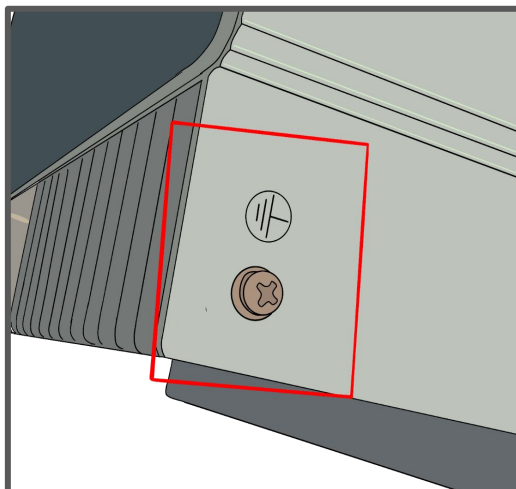

2

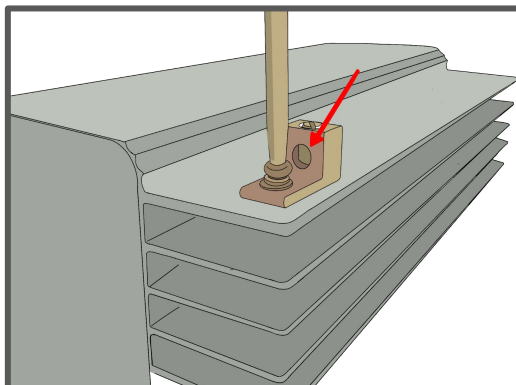

3

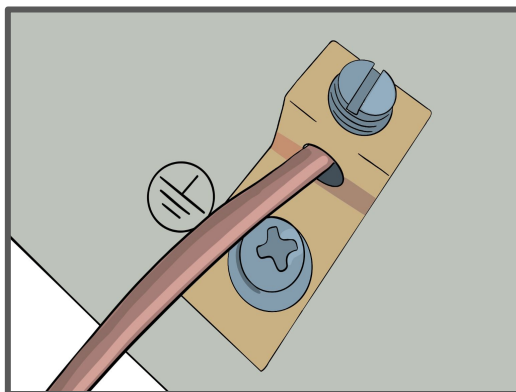

4

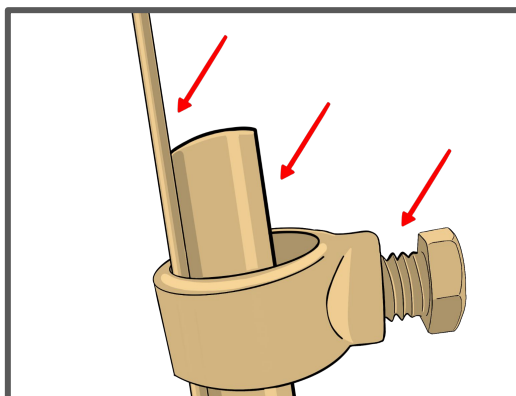

PUMP ASSEMBLY

STEP 1

Remove the 4 nuts on the top of your pump motor. You will need a ½" wrench for this step.

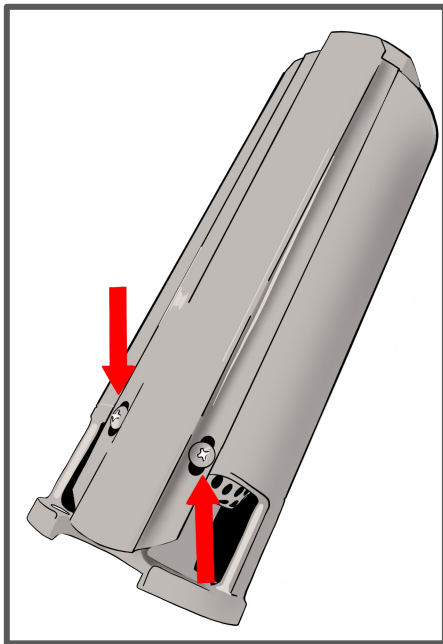
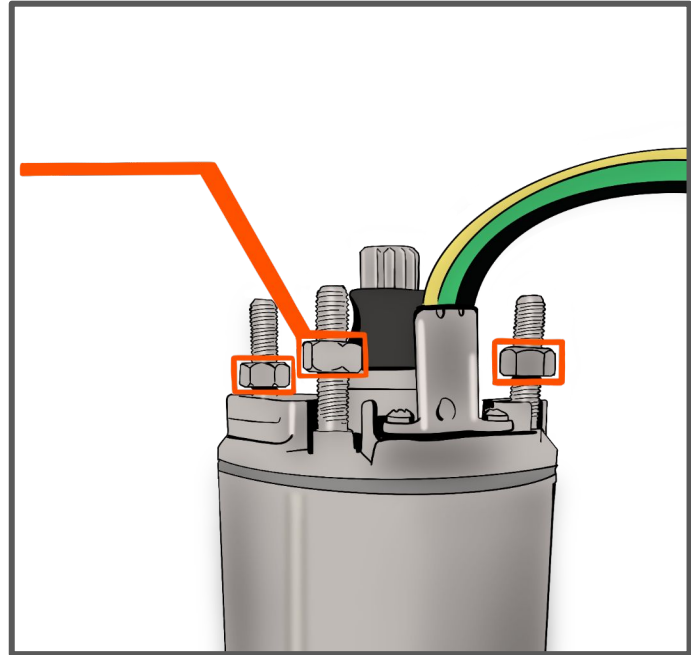

STEP 2

Remove the two screws on the wire protector located on the pump end. You will need a medium sized philips head screwdriver for this step.

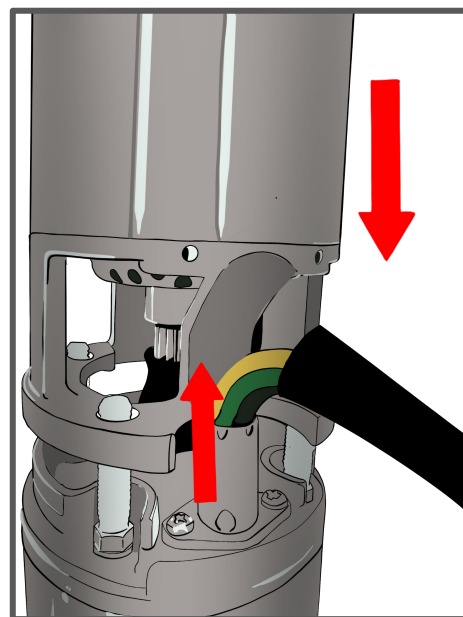

STEP 3

Place the pump end onto the pump motor allowing the bolts to pass through each of the holes. Be sure to align the wire groove on the pump end with the wiring harness coming out of the pump motor. Secure the nuts you previously removed. Hand tighten until snug and secure. The exact torque value is 10 lb-ft (14 Nm)

PUMP ASSEMBLY CONT.

STEP 4

Run the wires from the pump motor up along the side of the pump end where the wire cover will go.

PRO TIP: To make the installation of the wire cover easier make sure the wires lay flush along the pump end.

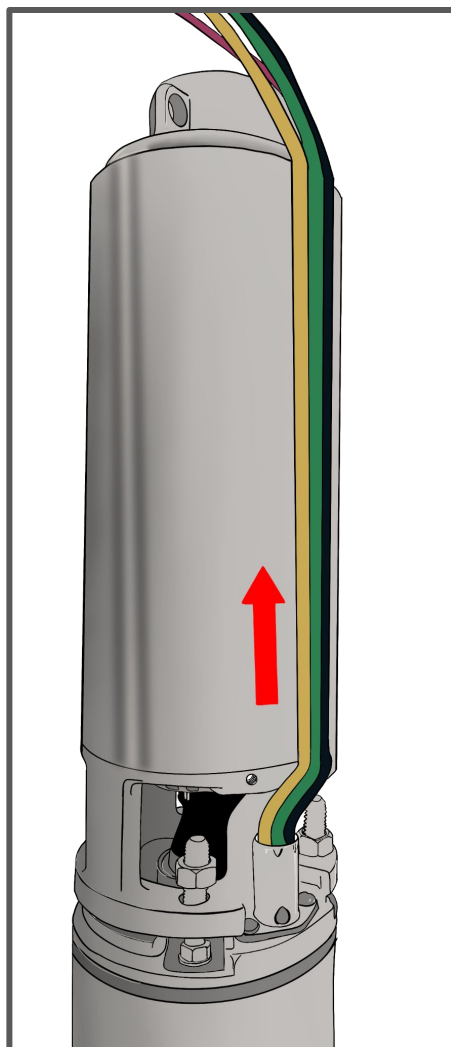

STEP 5

Install the wire cover by fastening the two screws previously removed.

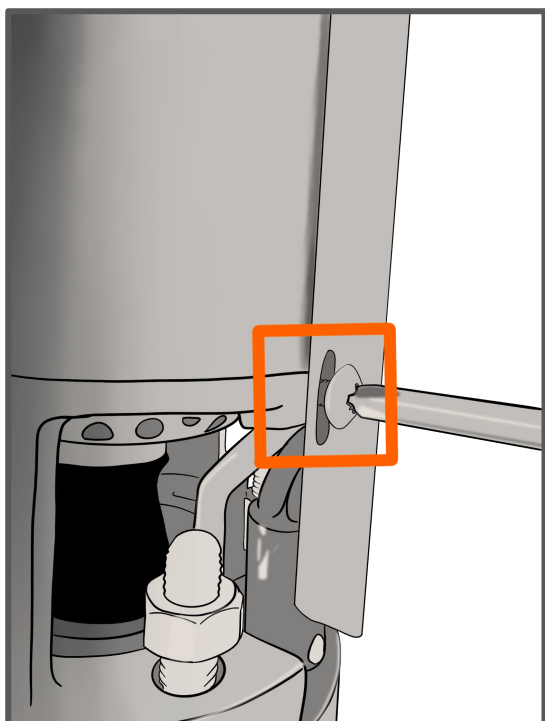

PRO TIP: The top of your wire cover is outfitted with a lip that fits securely over the sheath of your pump end. Secure this lip before fastening the screws to ensure proper fit.

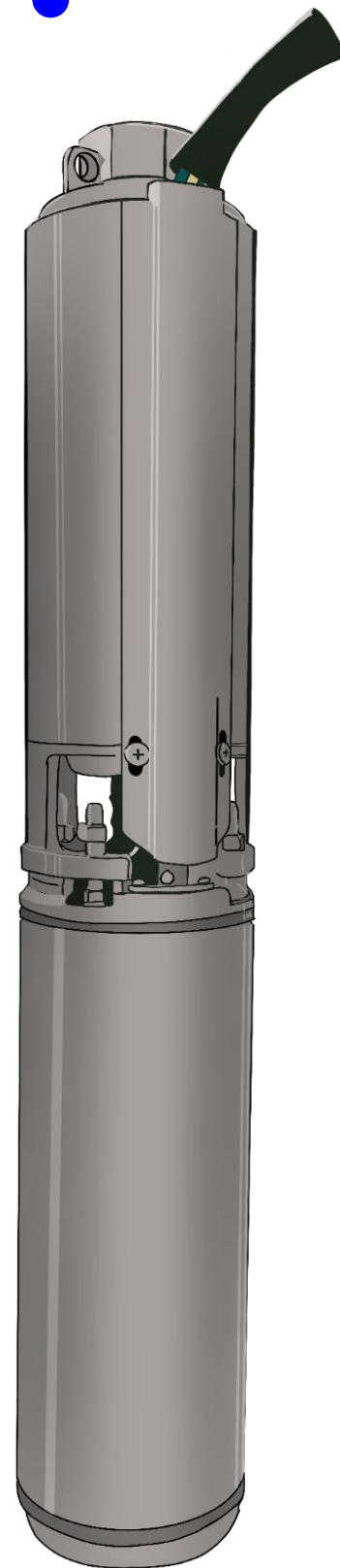
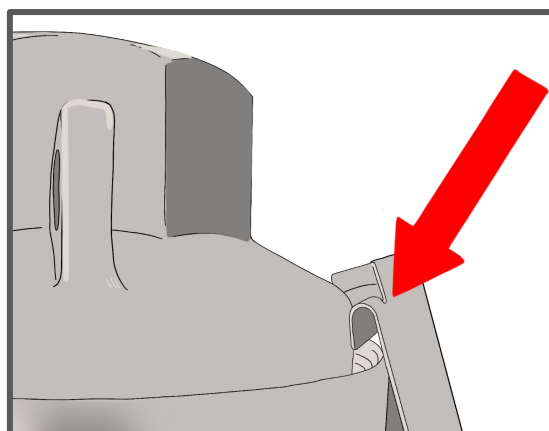

OTHER CONSIDERATIONS

Calculating pump head

DIAMETER

5 GPM

LENGTH		1.25"	1.5"	2"
	100'	negligible	negligible	negligible
	500'	3'	negligible	negligible
	1000'	5'	2'	negligible

50 GPM

	1.25"	1.5"	2"	4"
100'	46'	14'	4.5'	negligible
500'	231'	69'	232'	negligible
1000'	462'	139'	46'	negligible

The amount of total pump head (shown in feet) increases due to friction over long horizontal distance of poly pipe depending on the diameter of the pipe. Smaller diameter pipe adds more head to the system.

Connecting to a tank

To connect to a storage tank without using a check valve, make sure the pipe from your pump fills the tank from the top of the tank and not the outlet on the bottom. This will prevent the creation of a siphon back out of the tank when the pump stops. If you're using a check valve, you can connect to the bottom or top of your storage tank.

In a later section, we'll install the tank sensor and connect it to the controller if you're planning on using a mechanical float valve on the tank to shut off the pump, or if you are pumping into a pressure tank.

Well seals

You may already have a well seal, or you may be using a pitless adapter, which allows you to keep plumbing below ground. If not, you'll want to procure a well seal that allows your pipe, wires, and safety rope to exit the well while preventing any debris from falling into the well. This can be installed last, after testing and final installation of the system.

Check valves

For long runs of pipe, you may want to install a check valve. For any system using a pressure switch, a check valve is **recommended**. You'll need a 1 1/4 - 2" stainless threaded nipple to connect a stainless check valve to the outlet of the pump. The barb or your own plumbing will thread into the upper part of the check valve. Ensure the arrow is in the direction of flow.

Check valves are frequently made of brass and your pump is made of stainless steel; to prevent electrolysis use a PVC threaded nipple and a PVC barb for brass check valves.

Torque arrestors and spacers

Some traditional well installers are accustomed to using torque arrestors, but because RPS systems feature a slow-start and slow-stop, they don't create strong torque like an AC pump. For this reason, spacers and torque arrestors are far less commonplace in this setting. They can be used if you prefer, but are usually omitted during installation.

Debris filters

While some well owners choose to place a non-degradable well sock/mesh over their pump, this is unnecessary. All RPS pumps feature a filter screen that will prevent anything large from entering and clogging your pump.

Tank float

The tank float switch included in your kit is optional but very useful; when the water level in your tank rises to the level of the sensor, it sends a signal to the controller to shut down the pump and prevent your tank from overflowing. You can install this sensor at the top of your tank or wherever you want the water level to stop rising. Extend as necessary with 16-22 gauge 2 strand wire.

PLUMBING & SAFETY LINE

At this point in the process it is important to prep a few items for later steps. If you take these extra steps in preparation you will thank yourself later.

Attach a safety rope through either of the two holes (or both) in the top of your Pro-Series pump. Polypropylene rope is best since it will not decay however you can use a chain or stainless-steel cable if desired.

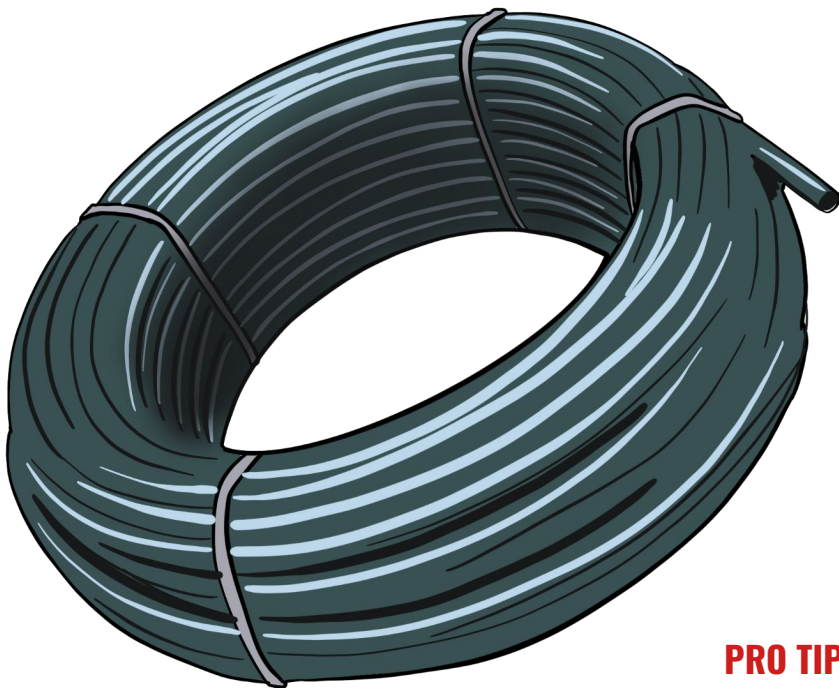
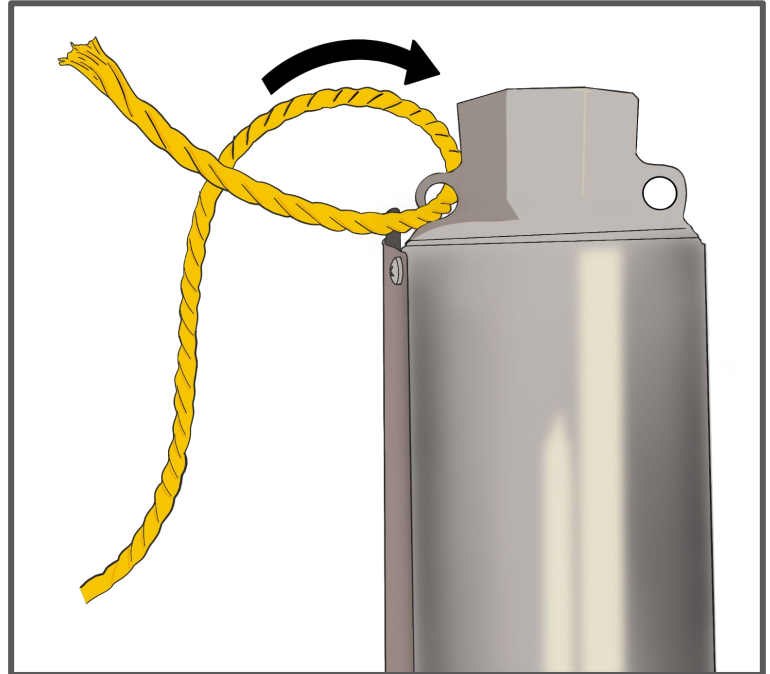

What you choose to use for the piping for your pump is completely up to you. We recommend poly pipe. If you are using poly pipe you are going to want to unspool the piping now. This step is especially important if the piping, or the surrounding weather is cold. Laying out the pipe now will make it so you don't have to fight against the pipes natural curvature while lowering down the pump.

After the pipe is laid out, run your heavy duty submersible flat jacket pump wire and your safety rope along the length of the pipe. Once this is done adhere the three lengths together using electrical tape and wrapping two to three times about every ten feet.

PRO TIP: Leave a little extra slack in the wiring and safety pop as polypipe can stretch up to 1% in the well. That's equal to 1 foot for every 100 feet of poly pipe.





WELL PUMP PLUMBING WITH POLY PIPE

If your installation requires a check-valve, (for example installs that also have pressure systems) you will need to install all three of these plumbing pieces: a threaded nipple, a check-valve, and a hose barb, in that order.

Your RPS Pro-Series submersible pump already has an internal check-valve installed, but it is recommended to install a dedicated check valve when used in a pressure system and other installations where you want to ensure no leakage.

For other open discharge applications you can install the hose barb directly to the outlet of your pump.

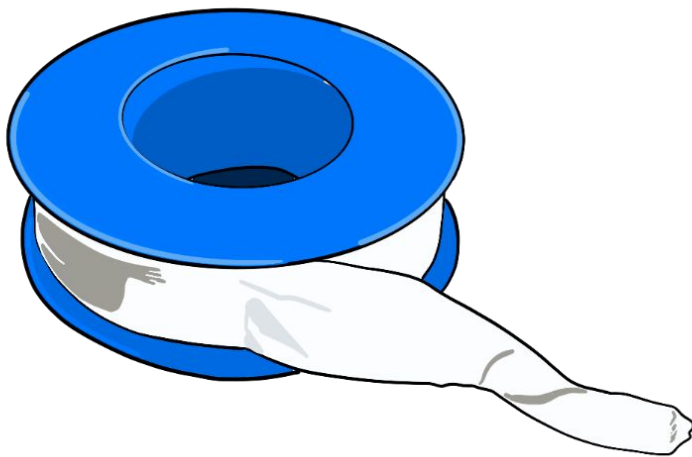

When installing any of the following plumbing pieces to your pump be sure to use 3+ wraps of teflon tape around the threads. Stainless steel can be more difficult to seal, so extra tape or pipe dope can help. Doing this will ensure that your fittings are secure and provide peace of mind.

PRO TIP: When wrapping teflon tape on any threads, wrap the tape going clockwise to avoid the tape being unraveled when threading on additional plumbing.

Connecting the pump to the drop pipe

Using the hose barb included in your kit and Teflon tape, screw the male thread of the hose barb coupling into the female NPT pipe thread outlet of the pump. Thread the hose clamps over the pipe and out of the way, then insert the end of your poly pipe over the hose barb end of the coupling. In cold weather to make the tightest connections possible, apply even heat from a heat gun to warm up the poly pipe; this increases malleability and allows the pipe to fit snugly over the barb. While the poly pipe is warm, tighten the hose clamps over the poly pipe and barb.

Pro tip: use a socket set on the hose clamps instead of a screwdriver for a tighter fit.



Hose Barb

Optional



Check-valve

Make sure to install your check-valve with the arrow pointing with the flow of water (away from the pump.)



Threaded Nipple

USER MANUAL

After you install your hose barb you will need to attach your piping, but first you will need to figure out what your outlet will look like. We recommend using a well seal assembly. A well seal is a metal assembly with three holes on the top. Under the face there is a rubber seal that will seal your well. Be sure to choose the right diameter well seal depending on the well casing size. This is measured from the inner diameter of your casing.

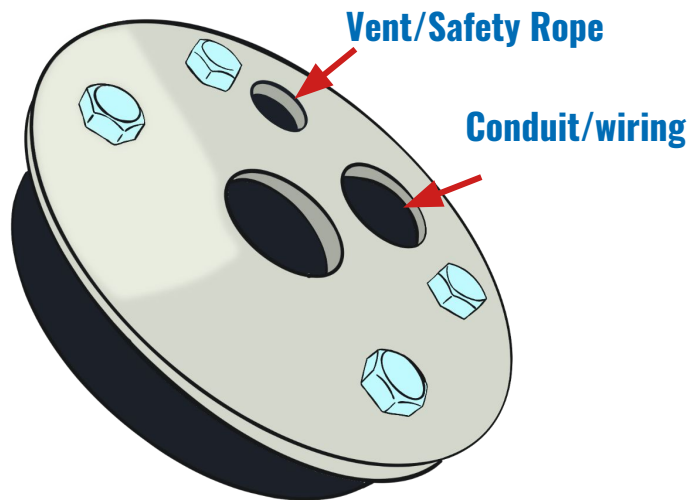

When you have your well seal you will want to put the assembly together. Start by putting the hose barb into the poly pipe and secure with three hose clamps alternating positions as pictured below.

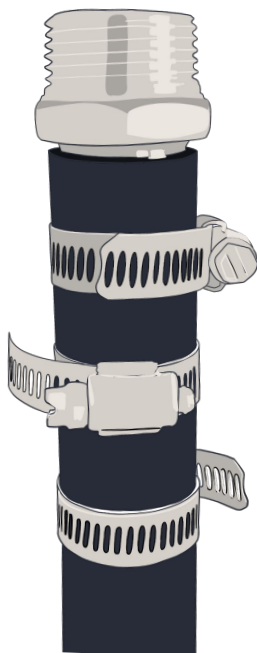

PRO TIP: it will be very difficult to push your piping down over your hose barb, this is by design. To make the process easier, especially in cold weather, use a heat gun or torch to heat the poly pipe slightly. The further down the hose barb you can get your pipe the better; however, it is not required to cover the entirety of the hose barb.

** In freezing climates it may be necessary to use a pitless adapter. In this case, the threaded barb will thread into the pitless adapter and be dropped into place deep in the well with your T Puller.

EXAMPLE OF WELL HEAD PLUMBING WITH POLY PIPE AND WELL SEAL

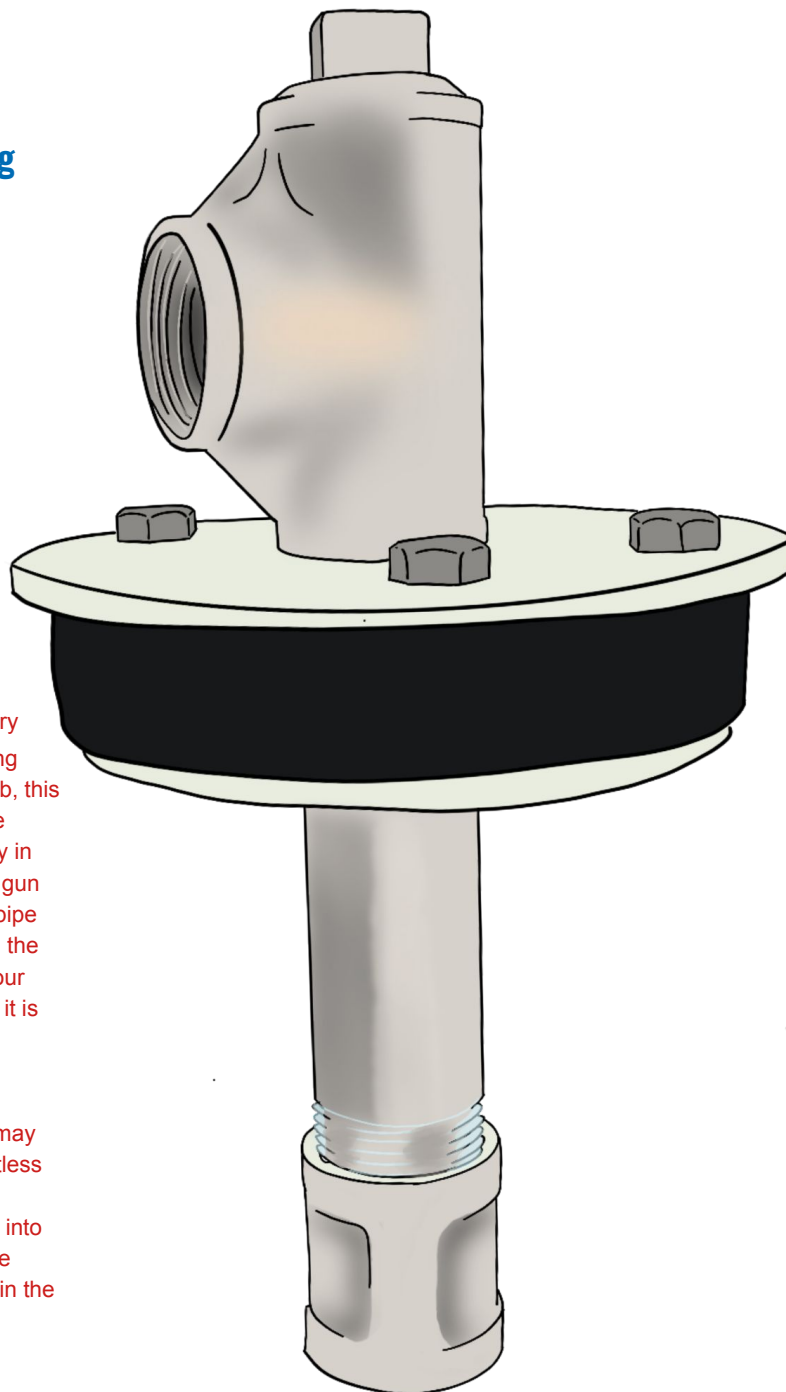



SOME NOTES ABOUT PLUMBING

Pump plumbing (drop pipe)

Length

Most commonly, solar well pumps are placed 20–30' below the water level. You may be able to set the pump even shallower if you know your well is a good producer and your water level won't decrease at your intended pumping rate. If your well has a very slow recharge rate, we recommend setting the pump as far as you can below the static water level (Pro series submersible pumps can be placed a maximum of 500ft below the water level).

Attempting to submerge the pump any deeper can damage your pump and void your warranty.

Diameter

Generally, 1 ¼ to 2" diameter is the most suitable size for drop pipe and accommodates the water volume of our systems.

Pressure rating

We recommend using poly pipe rated to 160 psi, up to 300'. This is rigid-walled to prevent kinking as you work with it, but is not overly cumbersome. Poly pipe rated higher than 160 psi is acceptable as well up to 300', but keep in mind that it will be heavier and will require more heat to become malleable when connecting barbs and hose clamps (see below).

For installations past 300ft down to 500ft, 250PSI poly pipe can be used.

For installations 500ft+ it will be necessary to switch to SCH120 PVC or galvanized steel pipe.

A note about poly pipe

Historically, well pumps were installed using rigid pipe— first galvanized steel, which was heavy and difficult to work with, and then rigid PVC, which, while lighter and partially flexible, still needed to be screwed together in 20' lengths. The drawback of rigid pipe is that most of the time, a well owner needs a well pump professional or someone with a boom truck to pull their pump, leaving them beholden to a contractor to maintain, install, or replace their pump. Poly pipe, by contrast, can be installed easily by hand with one or two people depending on the depth of well; it's also lighter, doesn't corrode in water, and is suitable for drinking water. At RPS, we recommend poly pipe when possible because it ultimately gives you, the landowner, more control over your well.

SUBMERSIBLE PLUMBING WITH POLY PIPE

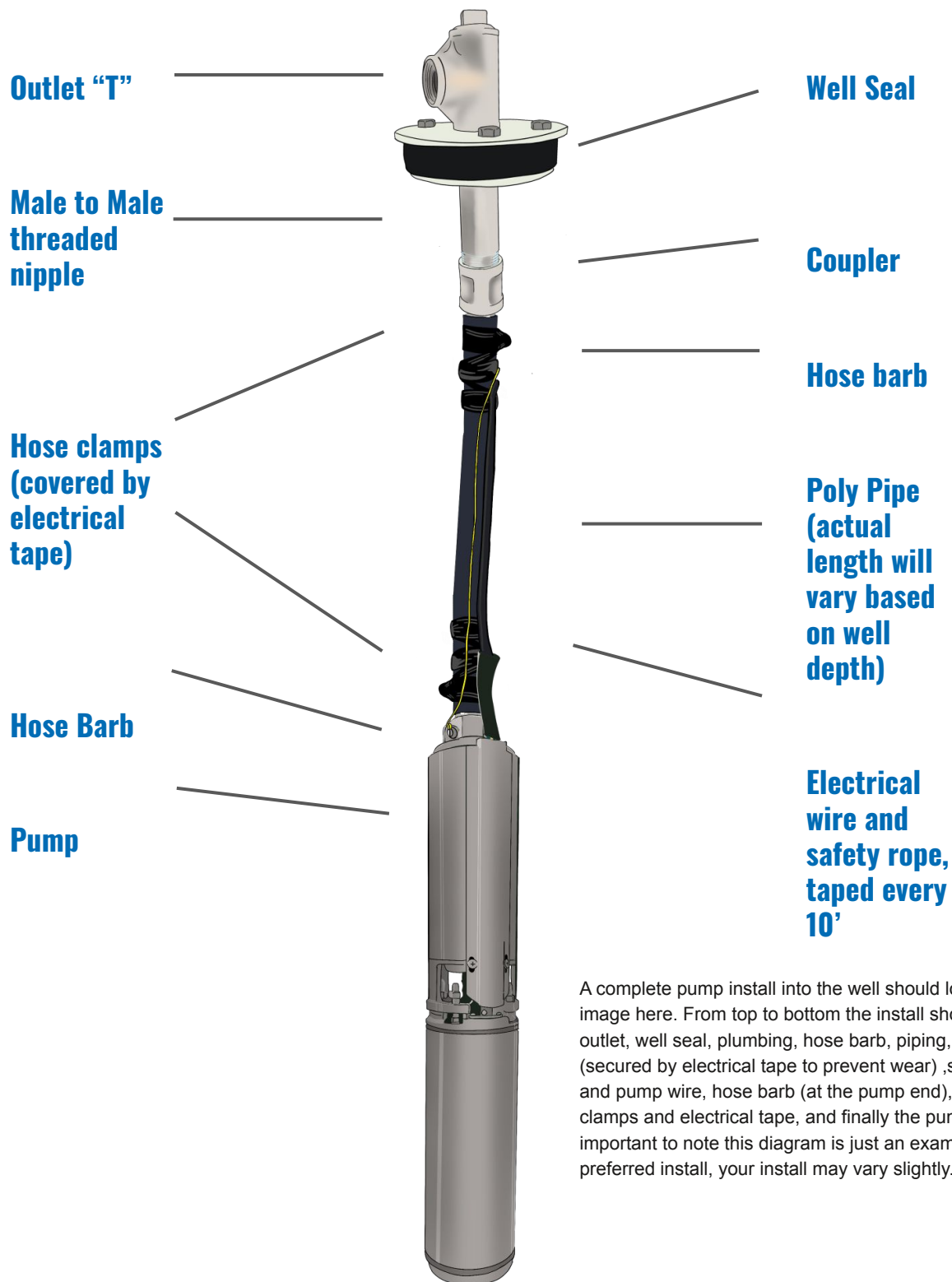

A complete pump install into the well should look like the image here. From top to bottom the install should include: outlet, well seal, plumbing, hose barb, piping, hose clamps (secured by electrical tape to prevent wear), safety rope and pump wire, hose barb (at the pump end), more hose clamps and electrical tape, and finally the pump itself. It is important to note this diagram is just an example of our preferred install, your install may vary slightly.



DEWATERING PLUMBING

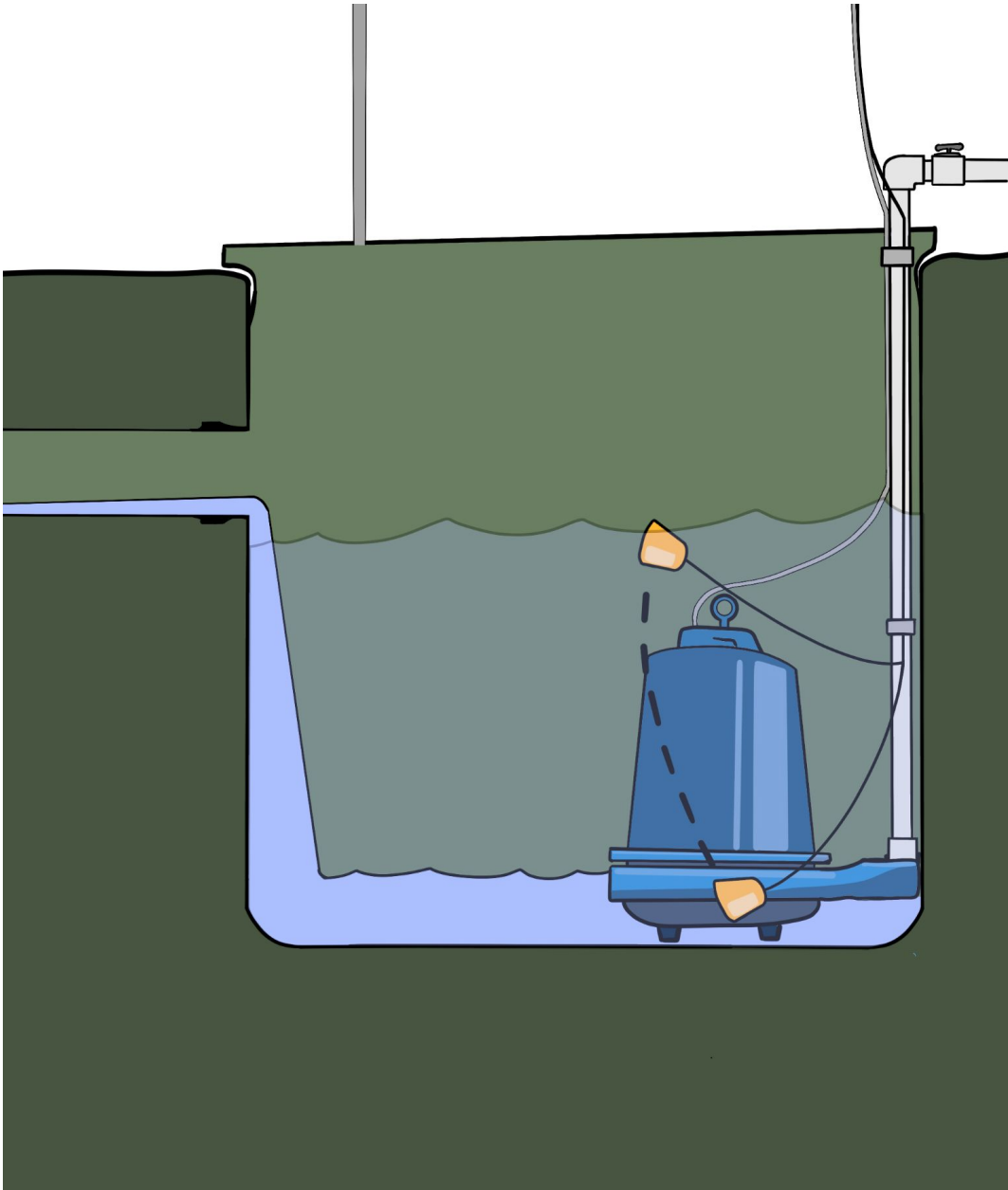

GB BOOSTER PLUMBING OPTIONS

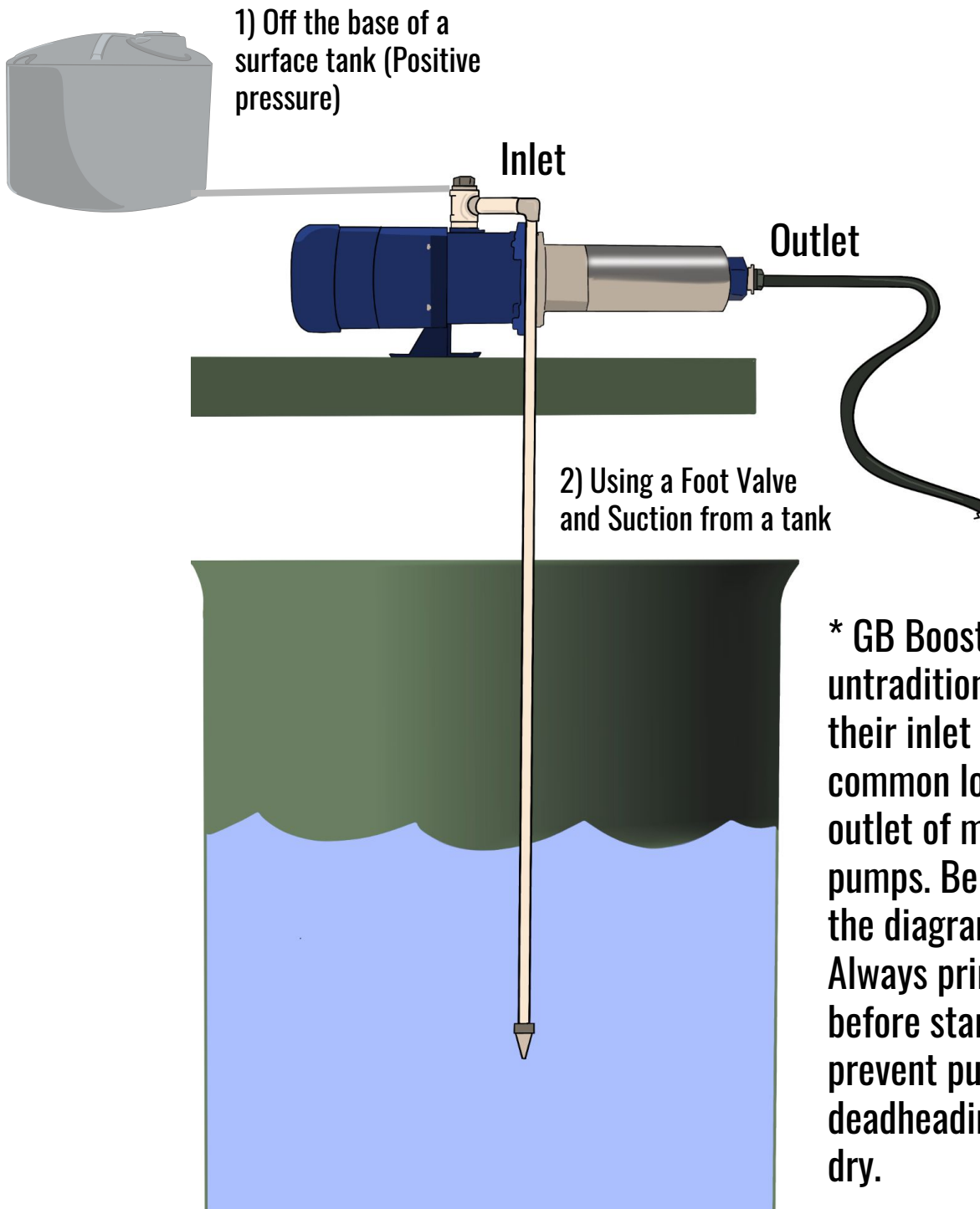



SURFACE PUMP PLUMBING OPTIONS

1) Off the base of a surface tank - positive pressure makes priming easier

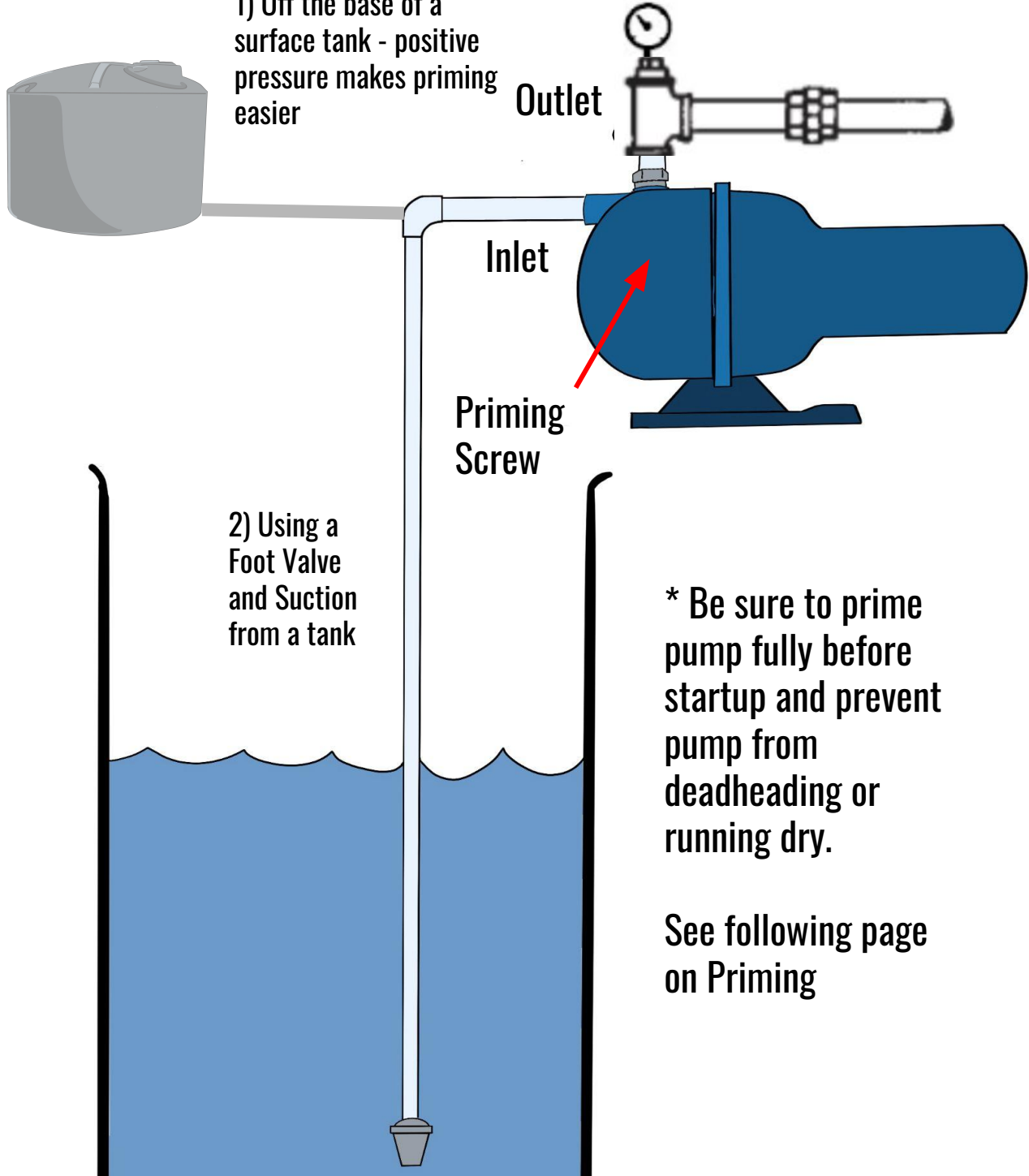

2) Using a Foot Valve and Suction from a tank

* Be sure to prime pump fully before startup and prevent pump from deadheading or running dry.

See following page on Priming



SURFACE PUMP INSTALL

POSITIVE PRESSURE PRIMING

(Example: Above Ground Tank)

1. Loosen Priming Screw.
2. Create positive pressure in supply line to push water into pump inlet or fill line with water.
3. Once air is completely purged, power on the pump to purge air completely before fully tightening Priming Screw again.
4. Adjust Pressure Setting with controls. Pump will adjust speed and smoothly cycle on & off to maintain desired setting.

SUCTION PRIMING

(Example: Buried Cistern or Spring)

1. Fill pump and supply line from the pump outlet Tee in the plumbing above the outlet, or through priming screw hole.
2. Once air is completely purged, power on the pump to purge air completely before fully tightening Priming Screw again (if your model has one).

Once pump is initially primed, (filled with water), it will re-prime when the water level rises above the end of the suction pipe. Most install an airtight union in the suction line close to the pump. Installation of a foot valve at liquid source is required. For installation with long suction piping, both a foot valve and a check valve are recommended. Increasing pipe diameter of suction pipe is encouraged. To avoid air pockets, no part of the piping should be above the pump suction connection and piping should slope upward from liquid source. For installations with long suction piping, fill the suction pipe with water before connecting to pump. Install a tee at the discharge connection of the pump to allow for filling later.

**** ALWAYS ****

- Allow adequate space for servicing and ventilation. Protect the unit from weather and water damage due to rain or flooding or freezing temperatures.
- Piping should be no smaller than the suction and discharge connections and kept as short as possible, avoiding unnecessary fittings to minimize friction losses.
- All piping **MUST** be independently supported and **MUST NOT** place any piping loads on the pump. **NOTICE: DO NOT FORCE PIPING INTO PLACE AT PUMP SUCTION AND DISCHARGE CONNECTIONS.**
- All pipe joints **MUST** be airtight and Teflon™ tape or equivalent is recommended for **ALL** joints.





WIRING YOUR PRO CONTROLLER

Once your pump is assembled, it is time to set up your Pro controller. The back of your Pro-series controller has the following connections. An easy-to-connect pump wire port, an optional tank full sensor port, a keyboard input port, a standard set (or two sets for 5hp controllers) of MC4 solar panel connectors, and an AC backup port which can be connected to grid power or a generator for operating in non-ideal solar conditions.

The back of your controller has a simple mounting bracket, which makes hanging the controller quick and easy with the provided self-drilling bolts.

Once you have installed your controller we will start by connecting your pump wiring to your controller. In your Pro-Series accessory kit are two connectors like the one featured below. One has four connection points and is used for the pump wires. The second has three and is for the optional 220VAC input.

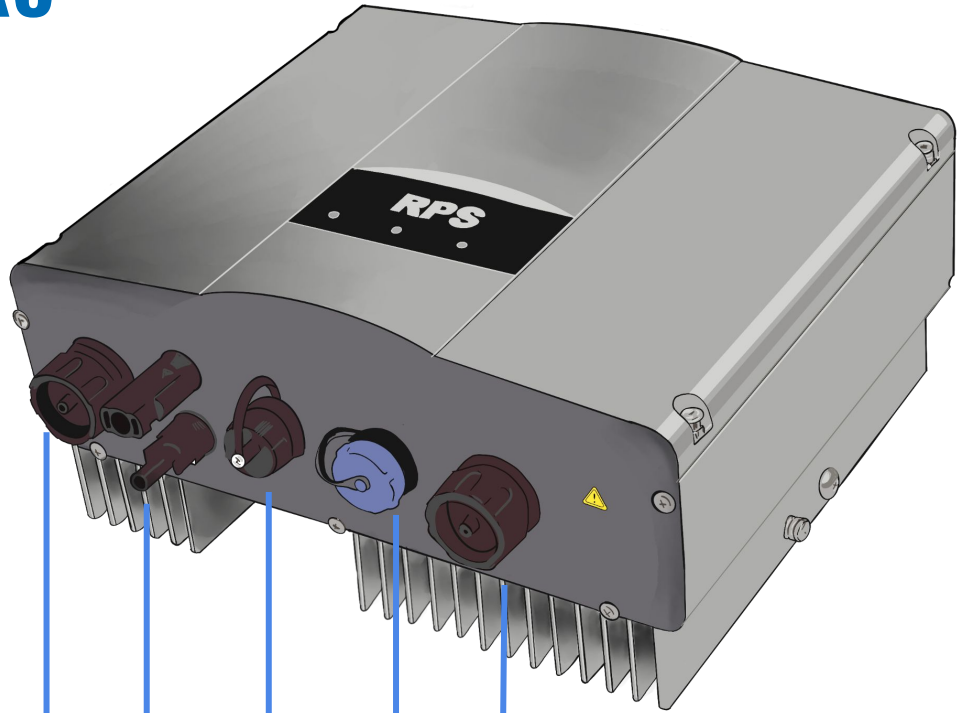

Easy connect port for pump wire

Optional tank full sensor

Keyboard input (for advanced settings)

Standard solar panel MC4 connectors

AC backup input (optional)



PUMP WIRING & CONNECTIONS

STEP 1

You will need a spool of heavy duty submersible flat jacket pump wire. Remove about 6 inches of the outer black jacketing to expose the colored wiring inside, be sure not to cut through the inner wiring jackets.

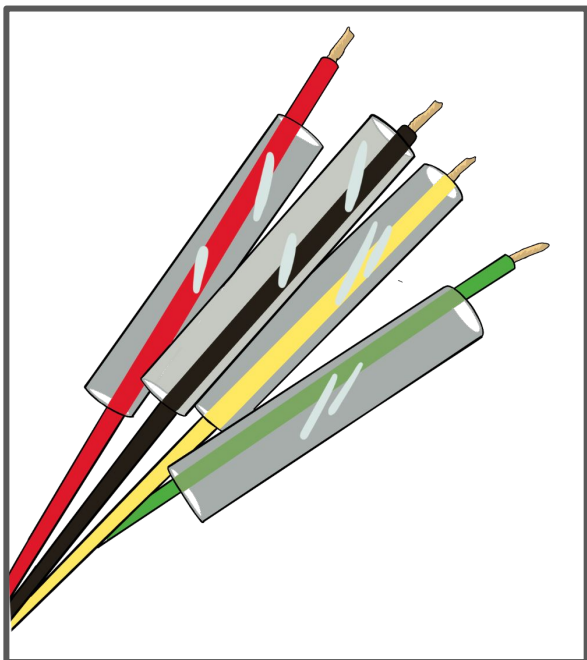
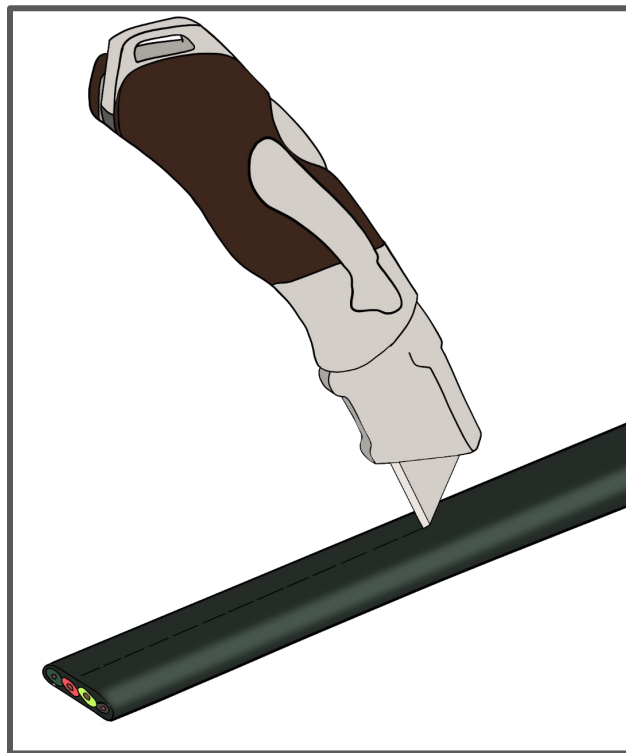

STEP 2

Strip both sets of wires $\frac{1}{4}$ inch length and place your heat shrink tubing over each strand of the wires coming from the pump motor.

STEP 3

Crimp the wires together, matching them by like colors if possible. Then using a butane torch/lighter or heat gun shrink the tubing over the crimp, creating a watertight seal. If using a lighter, move the flame quickly to spread the heat and prevent burning of the shrink tubing.

PRO TIP: When you seal the heat shrink tubing you want to see a small amount of adhesive squeezed out from the ends of the tubing

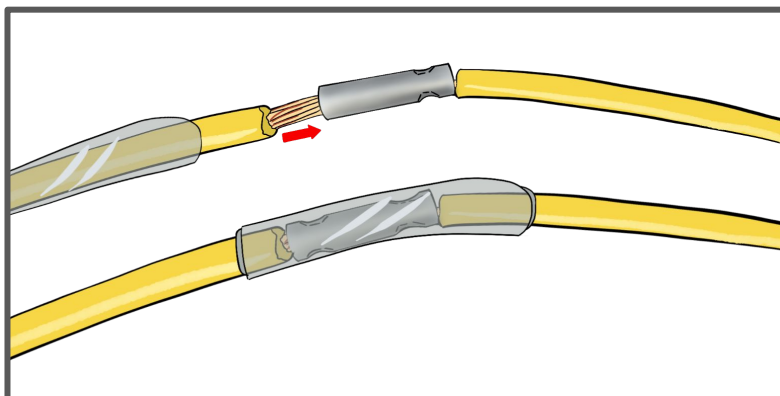



WIRING CONT.

Start with the pump connector which has four terminals.

NOTE: The connectors are indexed with grooves above ports 1 and 4 so they can only be inserted one way. If you are having issues inserting the connector, try rotating the connector.

Start by unscrewing the base of the connector.

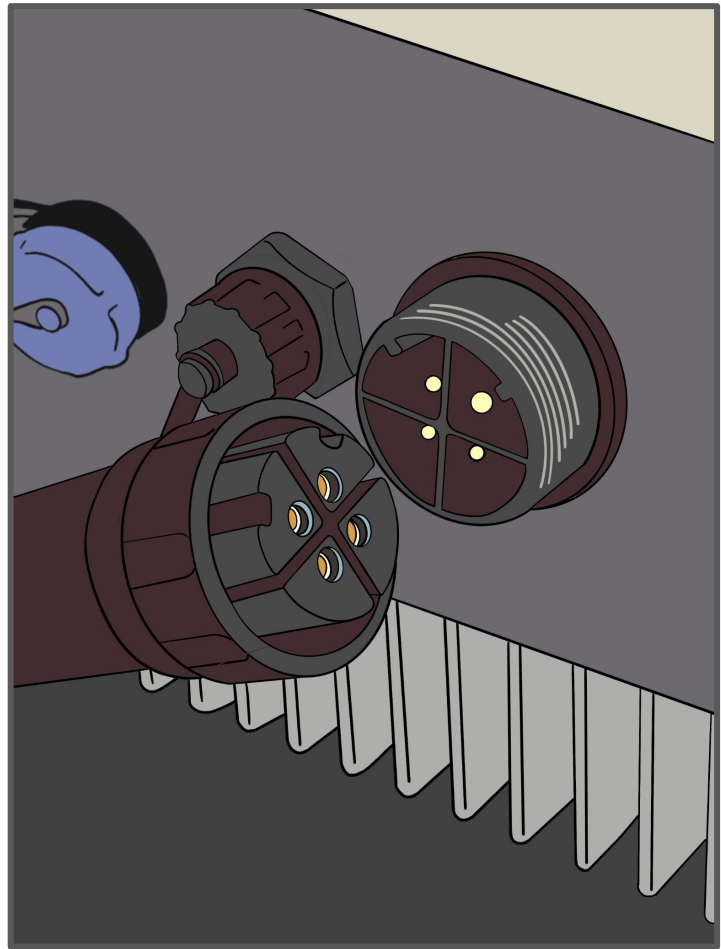
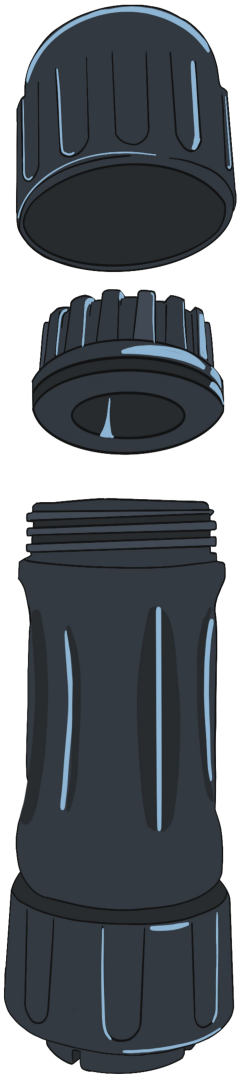

The cap will come off and a water resistant gland will be exposed, slip your wires through the cap and place the gland over the wires as illustrated.

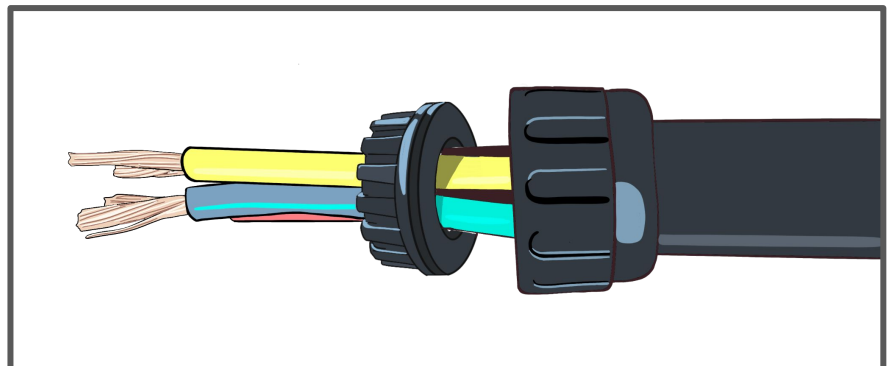



WIRING CONT.

STEP 1

When connecting the wires from your pump to your controller, start by removing about 6 inches of the outer black jacketing of the heavy duty submersible flat jacket pump wire to expose the colored wiring inside.

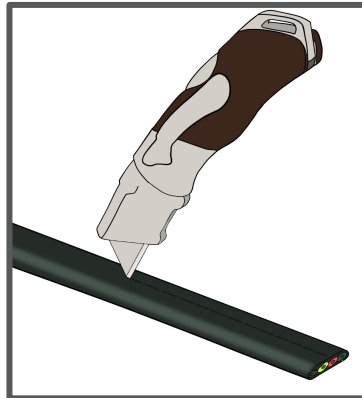

STEP 1

STEP 2

Strip the exposed colored wires ¼ inch in length.

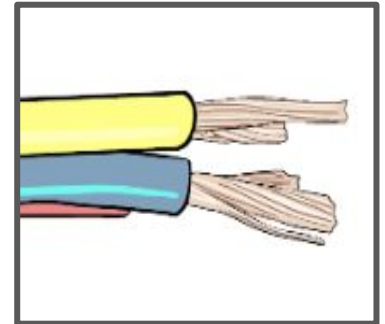

STEP 2

STEP 3

On the back end of the controller wire port, use the provided allen wrench to back out each of the crimping screws.

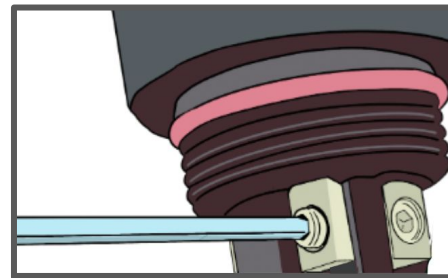

STEP 3

STEP 4

Using the provided diagram place each of the exposed wire ends into back of the appropriate terminals. (The connector is also labeled with these numbers.)

- RED -> Port 1
- BLACK -> Port 2
- YELLOW -> Port 3
- GREEN -> Port 4

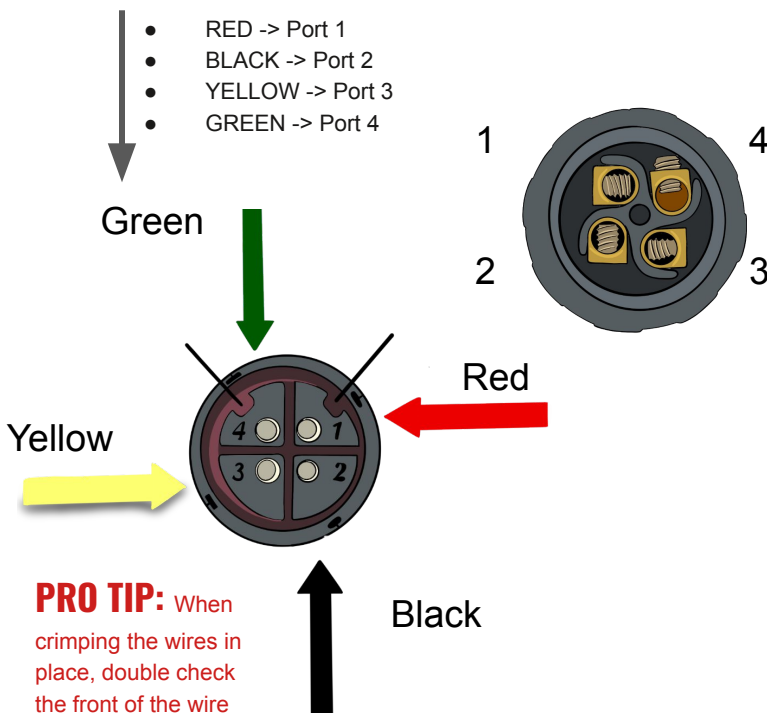

PRO TIP: When crimping the wires in place, double check the front of the wire port to make sure the wire is in the correct port.

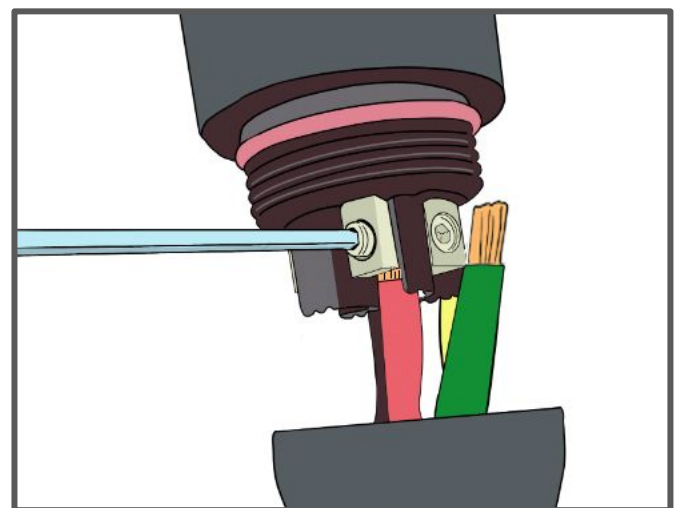

STEP 5

Using the provided hex wrench, tighten the set screws, securing each of the wires in place.

If using wires thicker than 10awg, it may be necessary to remove some strands to fit in the terminal. This will in no way affect the performance of the system.





WIRING CONT.

STEP 6

Once your wires are crimped into the connector, slide the rest of the adapter up and connect the body of the adapter to the adapter head.



STEP 7

Finally, once your pump wire is connected simply connect your adapter to your Pro Series pump controller!

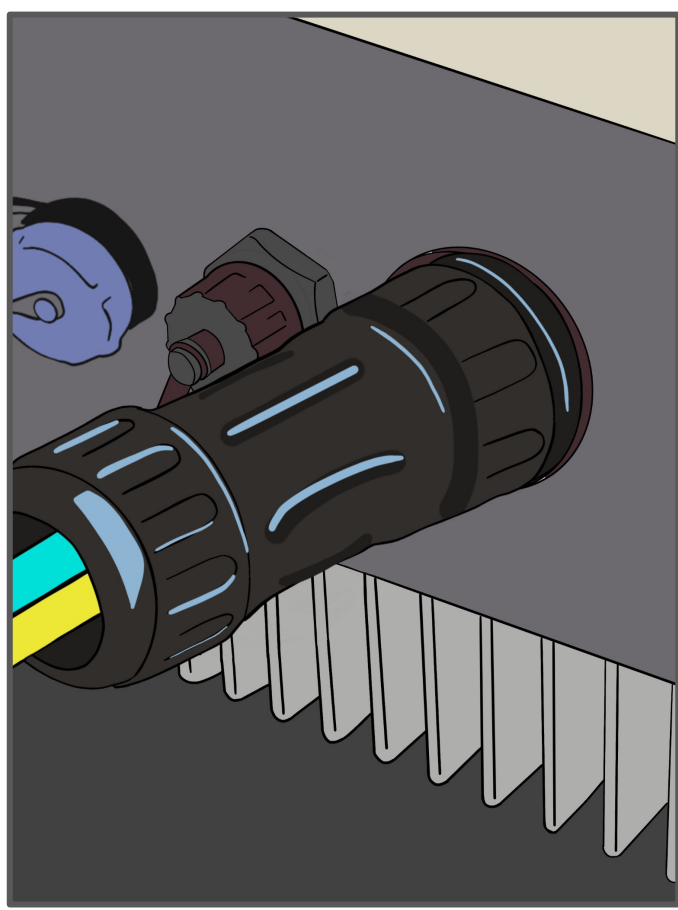
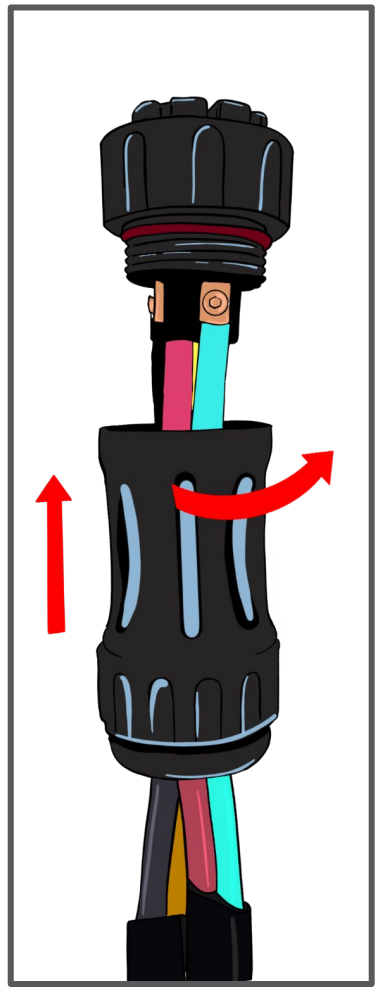

Your pump and controller are now connected!



CONNECTING THE SYSTEM TO AC POWER

Your controller is capable of switching between solar power and 220v AC (Generator or Grid) automatically. **This feature is optional and most systems run exclusively on solar.**

You'll be plugging into the AC Input Port on the bottom of your controller. The input plug is similar to your AC output that was wired previously but with only three pins. One pin is located between two alignment tabs. This is where the ground wire is inserted. The other two pins are Line 1 and Line 2.

If connecting a generator, the most common 220V receptacle is a NEMA L14-30R which is a twist lock 4 prong receptacle. This receptacle receives the corresponding L14-30P plug. There is no neutral line needed, so this wire can be cut off or capped if present, leaving Ground, Line 1, and Line 2 for the connection to the Pro Controller AC input plug.

The ground prong can be uniquely identified by its 90° bend and is usually green. The neutral is located on the opposite side of the ground and is often identified by a bright silver terminal screw. Line 1 and Line 2 are adjacent to the ground prong and typically have brass terminal screws on the plug.

PRO TIP: When discussing "220V AC" power, this is generic for 220VAC, 230VAC and 240VAC which all meet the same North American power standard and are acceptable for the controller.

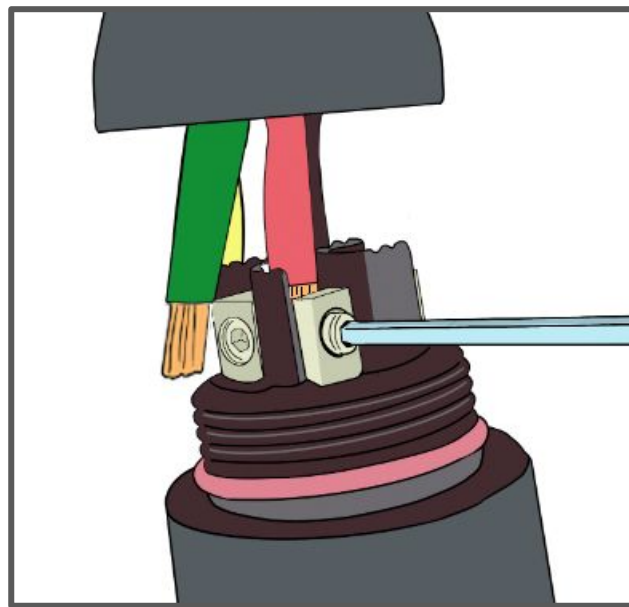
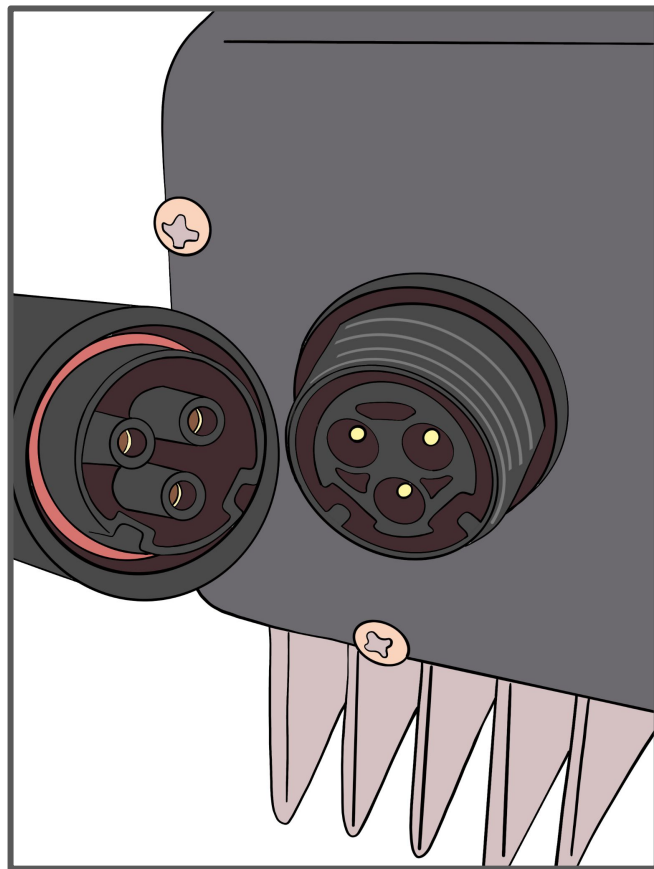
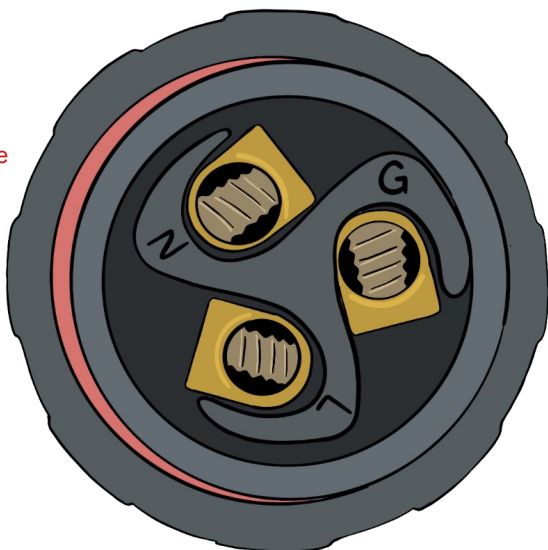

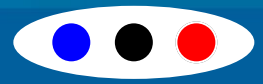

ELECTRICAL SPECS & BREAKERS

	500	750	1000	1500	2000	3000	5000
Voltage	220V	220V	220V	220V	220V	220V	220V
Amps	1.5-2.8	2-3.8	2.2-4.6	2.9-5.9	3.8-7.5	5-10.1	9.8-17.5
Max Amps	2.9	3.9	4.7	6.1	7.6	10.1	17.6
Peak Wattage	610	850	1100	1500	2000	2880	4925
Most Common Breaker Size	15A	15A	15A	20A	20A	20A	30A

Using Generators with RPS Systems

Pump Model	220V Single Phase
RPS Pro Series 500, 750, 1000, 1500, 2000, 3000 Well Pumps, Surface Pumps, GB, Dewatering Pumps, Trailer	220V Input 6000W or greater recommended for proper VFD functionality at full Hz. <i>Smaller 220v generators may not operate at full 60 Hz</i>
Lakemaker XL 5 HP, ProW Dewatering 5HP, ProS Irrigation 5HP	220V Input 8000W or greater recommended for proper VFD functionality at full Hz. <i>Smaller 220v generators may not operate at full 60 Hz</i>

WIRING YOUR DEWATERING PUMP

The RPS Dewatering Pump is wired to the Pro controller using the wire coming off the pump. The pump wire splits into 4 colored wires: red, black, yellow, and green.

Using a splice kit you can extend your pump wire if you need more length on your dewatering pump. Using the provided diagram place each of the exposed wire ends into back of the appropriate terminals:

- RED -> Port 1
- BLACK -> Port 2
- YELLOW -> Port 3
- GREEN -> Port 4

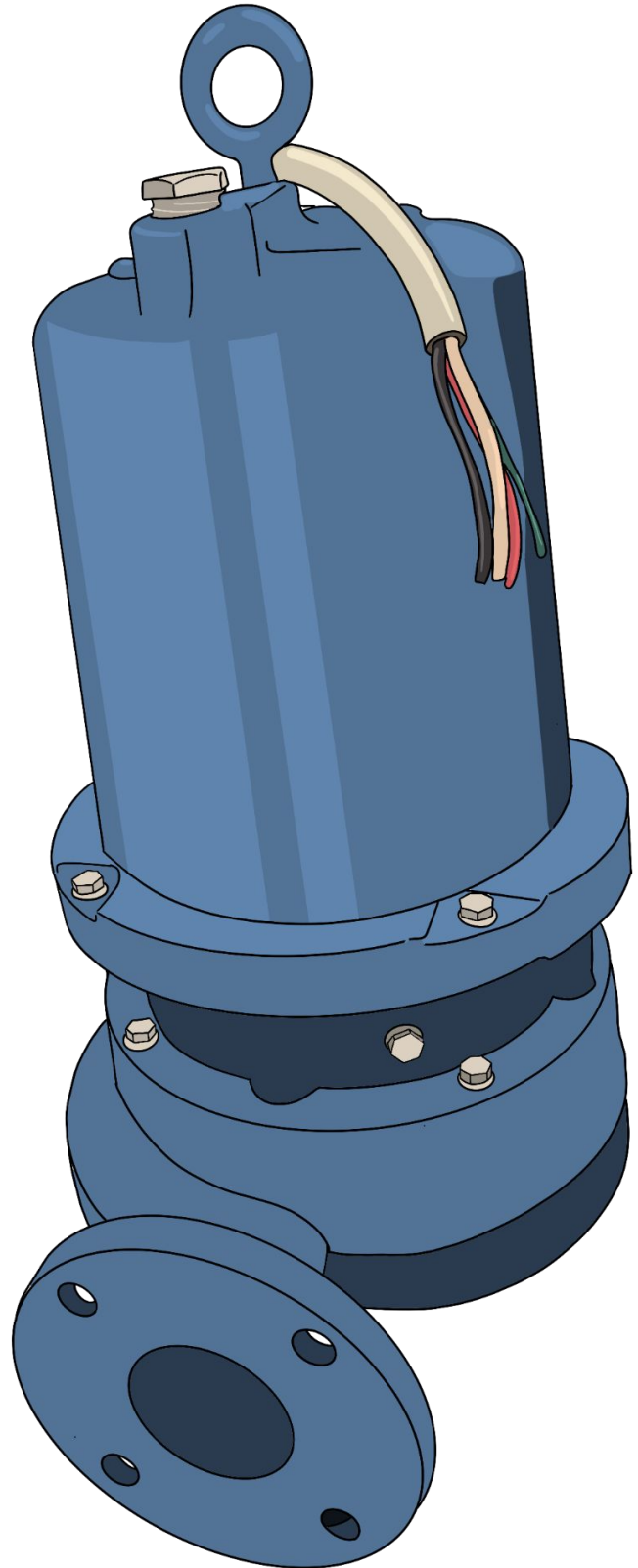
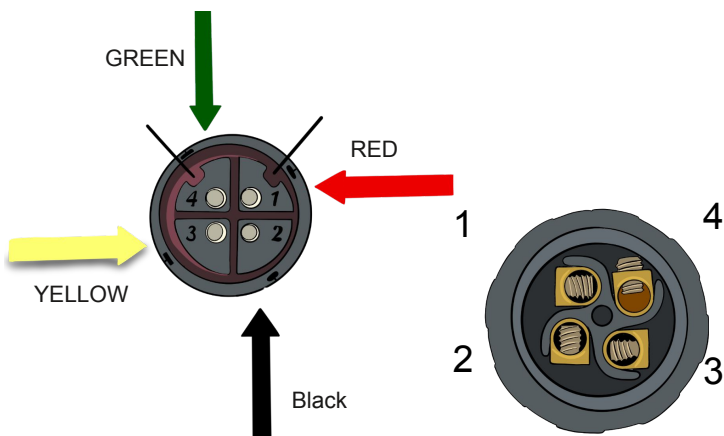
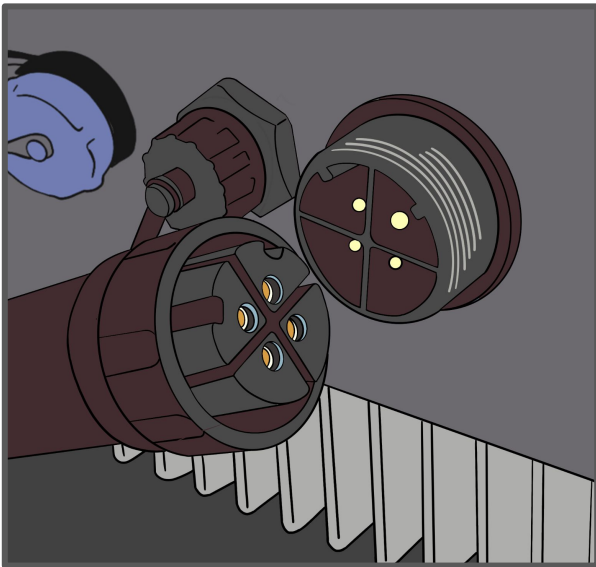

WIRING BOOSTERS AND IRRIGATION

The RPS Irrigation and GB Booster pumps are wired to the Pro controller using short wires and wire nuts. On the back of the pump is an access panel that can be opened with a flathead screwdriver and will reveal the wires inside. It may look like a mess of wires, but the wires you will be connecting to the extension wire are twisted together as shown on the following page. The wires that are wire nuted together will not be used to connect the extension wire, so leave those alone.

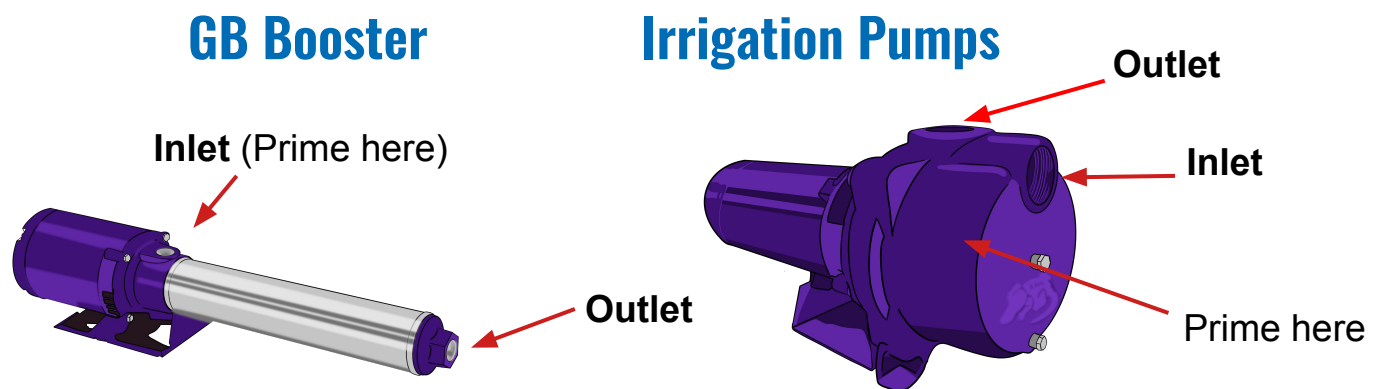

BE SURE TO PRIME YOUR PUMP BEFORE STARTUP

** Important: Care should be taken when plumbing to ensure tight connections and maintain prime. Use teflon tape or thread sealant on all connections. Minor leaks or seepage will cause the pump to cycle.*



WIRING BOOSTERS AND IRRIGATION

Open this panel on the back of your system.

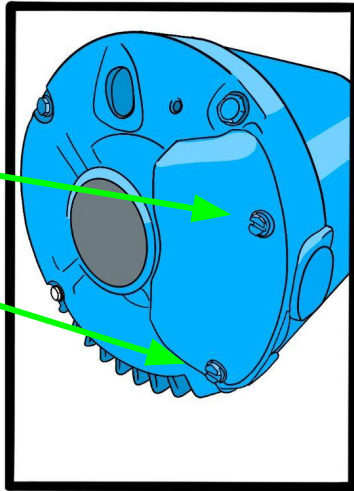

Wires
2,8= L2

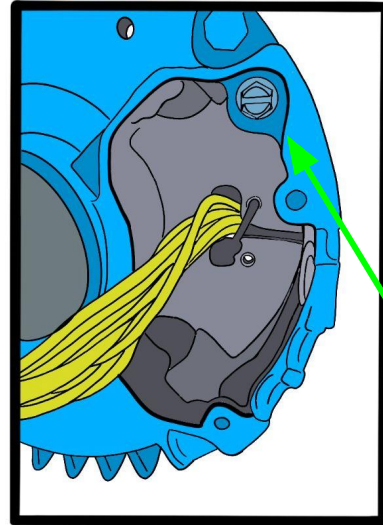

Grounding wire connects to this screw.

Wires
1,7= L1

Black wire from controller
Fasten with nut to wires 1 and 7

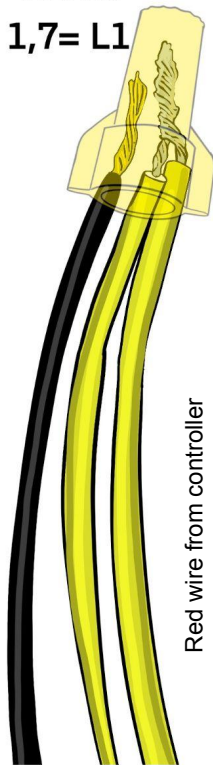

Red wire from controller
Fasten with nut to wires 2 and 8

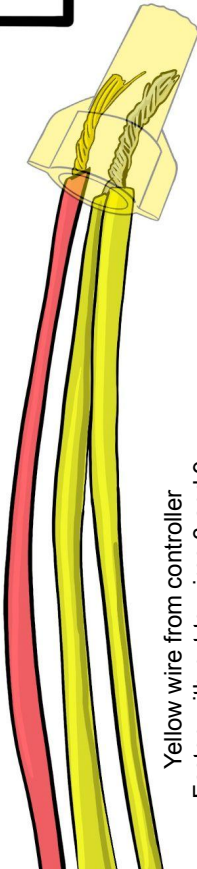

Yellow wire from controller
Fasten with nut to wires 3 and 9

Wires
3,9= L3

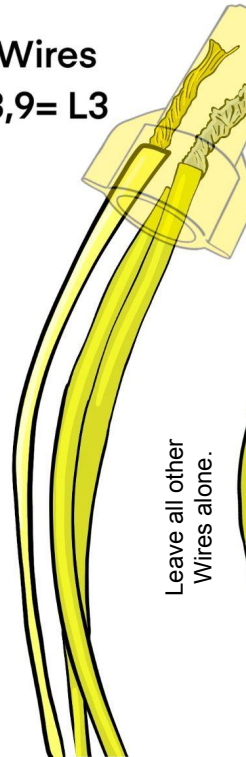

Leave all other
Wires alone.

Wires
4,5,6

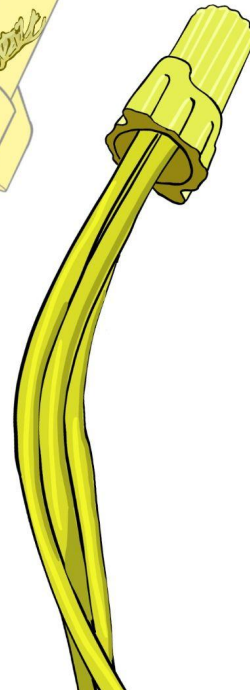

BUCKET TEST

When your pump is wired to the controller and the controller is ready to connect to either AC or DC power, do a bucket test prior to lowering the pump into the well.

STEP 1

Fill a large receptacle (water tank, garbage can, or tote will work) with fresh clean water.

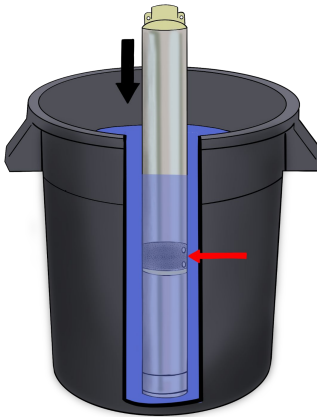

STEP 2

Place your pump into the receptacle. Ensure that the water level is ABOVE the center of your pump where the inlet is located.

STEP 3

After ensuring your pump is connected to the controller and submerged in the water, provide power to your controller. The system will automatically start when you connect your controller either to your panels or to your ac power source.

AC Power

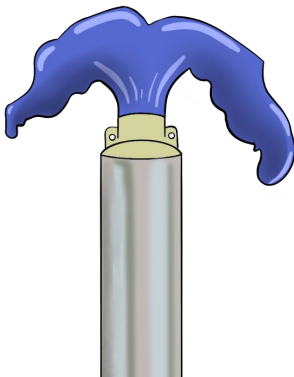
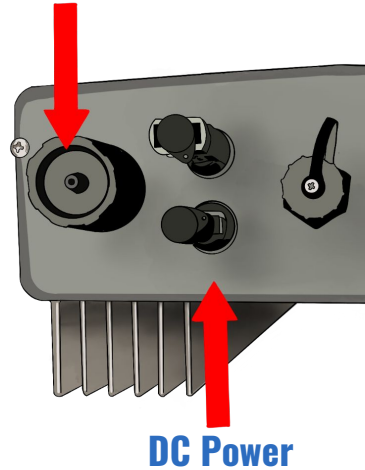

STEP 4

All RPS pumps use a slow-start/slow-stop so the pump will begin to pump water within the next 20-30 seconds. If the pump does not begin to gush water, check the troubleshooting diagram.



CHECKLIST: Are you ready to lower your pump?

Remember, **DO NOT** turn on the pump unless it's completely under water!

Watch at [RPSsolarpumps/install](#)

- You've read the manual and all the KEY STEPS in each section.
- Pipe connected to pump with barb and hose clamps.
- Length of drop pipe appropriate for setting pump. Don't rest the pump on the bottom of the well to avoid stirring up silt and sand.
- Safety rope attached directly to pump.
- Pipe, wires, and rope electrical taped together every 10–20'. Be sure to leave a few inches of slack in both wires to allow for the poly pipe to stretch a little on install.
- Solar panels in full sun with no shade anywhere on surface and correctly connected as on pg 16.
- DC Disconnect is set to OFF.
- Solar panel wires connected to MC4 connectors on the DC Disconnect. Confirm that the DC Disconnect is wired into the controller.
- Pump wire connected to 1, 2, 3 and ground terminals.
- Tested successfully in a bucket! **We highly recommend this step with deep wells, rigid plumbing, and when the 1,2,3 wires may have gotten mixed up during splicing or final connections!**





Using Sensor Shut Off (Float or Pressure)

When the water level in your tank rises it will lift the float switch. Once it rises to a sufficient angle it sends a signal to the controller to shut down the pump and prevents your tank from overflowing. You can install your float switch at the top of your tank or wherever you want the water level to stop rising. Extend as necessary with 16-22 gauge 2 strand wire.

The tank level sensor included in the kit connects to the solar pumping controller using the blue connector with the pigtail. It connects to the COM port (also blue) on the underside of the controller. The pigtail is a jacketed bundle of two smaller wires. Each of the two wires is pre-configured to connect to the correct switch inputs. Since the system will pump when there is no sensor plugged in (Normally Open) you'll want to use the two wires on your float sensor that close the circuit when the float is floating. There is an insert in your float switch with more wiring details.

When the float is hanging, the float should be telling the controller to pump and the circuit will be open. (This usually excludes the blue wire but a multimeter will give you a quick verification).

Strip the outer jacket to expose the two 18 gauge wires and strip 1/4" of insulation on each wire to expose the conductor. Use the included splice kit to connect to the two float switch wires. Alternatively, you may have chosen to operate your pump off of a pressure switch. Use some two wire sensor cable to connect between the blue connector and either of the two adjacent terminals on the pressure switch. Polarity on your float switch does not matter.

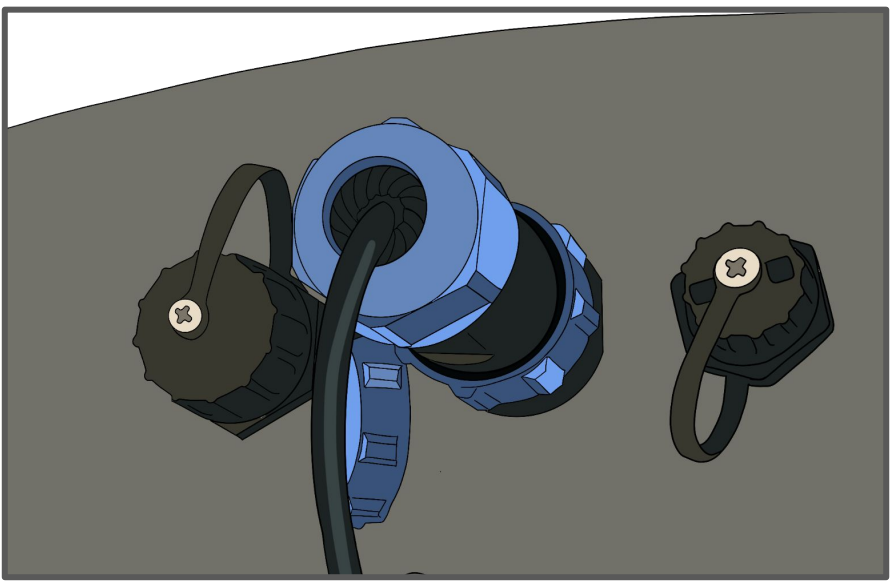
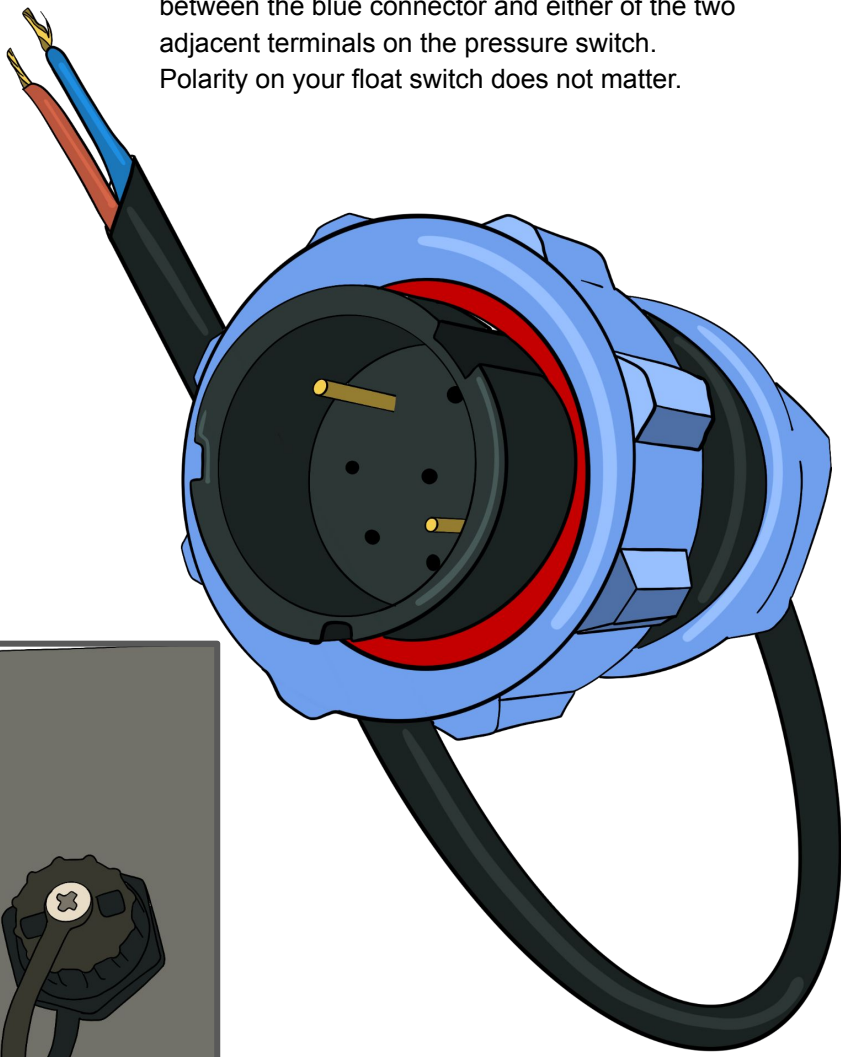



Using a Float Switch for Pump Shut off on Tank Full

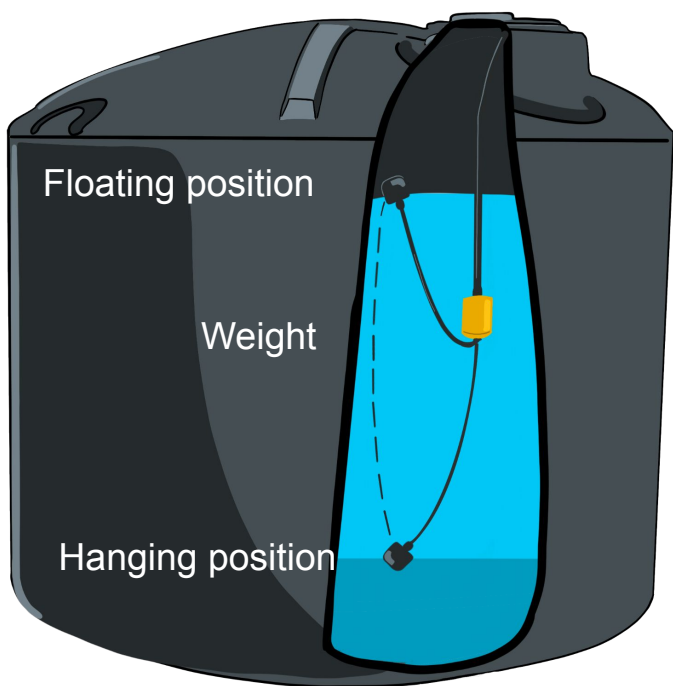

RPS Pro Series, Pro Irrigation, Pro Dewatering

Acts as an electrical signal that the tank is full.

Normally Open

Open circuit to tell the controller to pump when float switch is hanging, and stop pumping when it is floating and circuit is closed (ie. tank is full)

*Use **Black & Brown** Wires
Extend with 16-22 AWG 2 strand wire*

*Wire the two wires from the RPS Pro Controller's Tank Sensor pigtail to tank and connect to **Black & Brown** wires which will be an open circuit when hanging and a closed circuit when floating to shut pump down. Polarity does not matter, wires can be switched.*

When your float sensor is installed in your stock tank it will be anchored by the weight on the cable. The Float will float attached to the weight and when it reaches its apex it will send a signal to the controller letting it know the pump should be turned off. When the water is used throughout the day the float will change positions accordingly, letting the controller know that the tank's volume is decreasing and the pump should be turned on. The table above will tell you how those two signals will affect your pumping.

Adjustments:

- To adjust the "throw" (the volume of water used before the pump turns on), lengthen or shorten the distance between the float and the weight.
- To adjust the upper water level, adjust the length of wire between the tank and the weight.

Always ensure there is enough clearance for the float to move freely, especially if there is any other piping located in the tank.



CALL OR TEXT
530.240.3825



RPSOLARPUMPS.COM/PRO



SUPPORT@RURALPOWERSYSTEMS.COM



INDICATOR LIGHTS

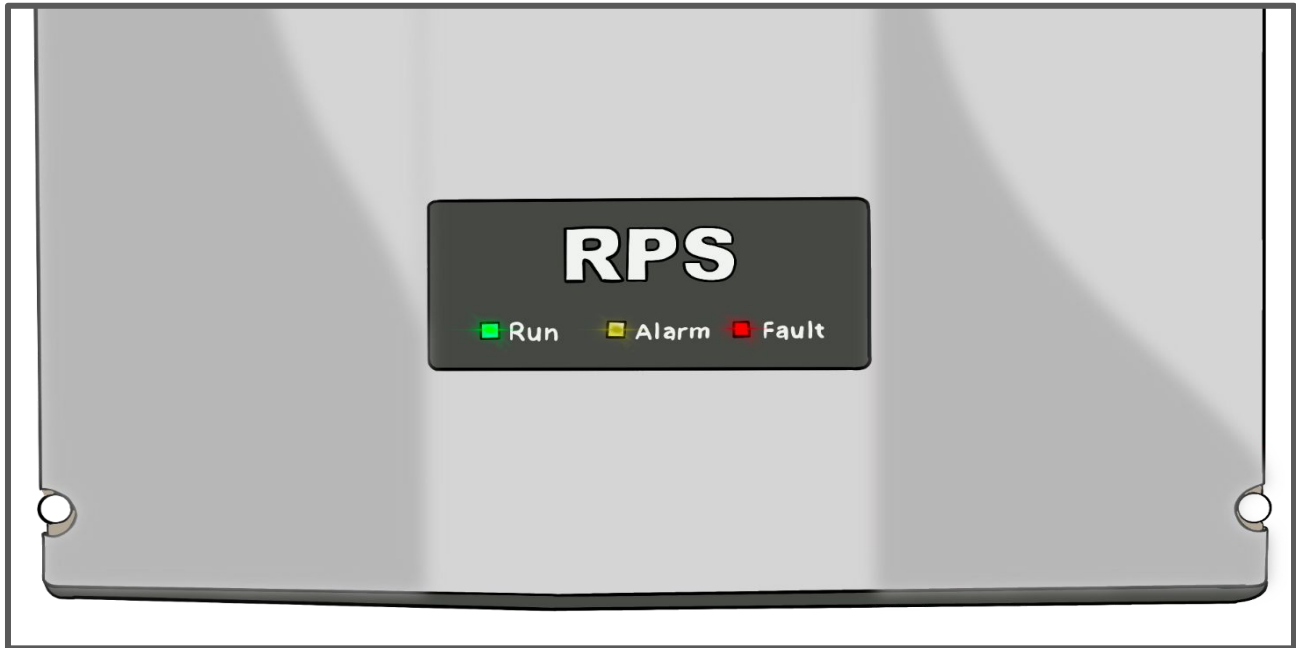

RUN - GREEN LED

- **STEADY GREEN** light means the pump motor is running normally between the minimum and maximum frequency.
- **BLINKING GREEN** light means that your system is in startup mode.

ALARM - AMBER LED - This is a normal stop condition. When the ALARM light is illuminated an external condition is sending a signal to the controller to stop pumping water. Pumping will only resume when the external condition is resolved. The most common conditions causing a stop condition are:

- The tank is full.
- There is insufficient light to run your system.
- There is not enough water in the well (sucking air) and pump is waiting on a preprogrammed time delay before it can resume.

FAULT - RED LED

- If the FAULT light is illuminated it means a fault condition has occurred within the controller. Usually this indicates there is insufficient power to the controller to power up the pump (check that your solar panels are in full sun with zero shade. Even a small shadow can have significant impacts to water production).
- It can also indicate a system or programming fault that will place the controller in Standby to protect it. A fault condition can be temporary and may require resetting the controller by cutting system power with the DC disconnect, waiting 60 seconds (no lights on!) and then powering back on to resolve the fault.
- If the fault occurs repeatedly you will need to connect your Keypad to the controller to read out the fault condition displayed on the red seven segment LED on the keypad. RPS Support Engineers can help troubleshoot in cases of repeated faults.

KEYPAD (Advanced Use Only)

*** DO NOT CHANGE SETTINGS WITHOUT ADVANCED KNOWLEDGE. USE ONLY IF DIRECTED BY SUPPORT.**

The Keypad included with your Pro System is used to check system runtime parameters, read fault status or stop condition details, or to reprogram the controller if system components change. Use the included connector cable and plug it into the back of the keypad. Unscrew the cover from the keyboard port and plug it in with the controller in the ON state. If you are identifying a fault condition, connect the Keyboard and read the fault before performing a hard reset on the controller which will clear the fault. **In most cases the system can run without ever having to connect the keypad. Most support calls are from customers who accidentally change settings when jogging through the various menus which can result in degraded performance or damage to the pump.**

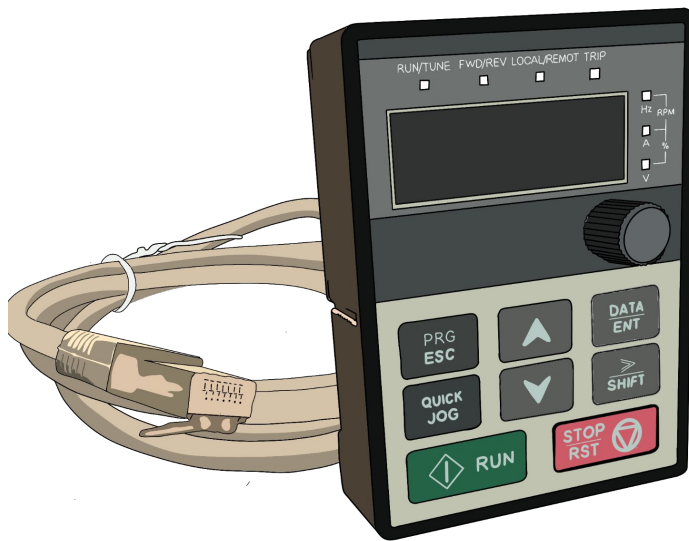

Operational State Parameters

The Keypad displays state parameters which assists in troubleshooting and system performance. **To view these values connect the keypad to the controller while the system is running and press the SHIFT button to advance through the values. The various indicator lights to the right will change to indicate which value is being displayed.** All values other than set frequency and bus voltage will change in real time depending on solar conditions, time of day, and panel angle. The Keypad will display the values, after connecting, in the following order:

Display Lights

Frequency	Top LED illuminated
RPM	Top two LEDs illuminated
Current	Middle LED illuminated
Percent	Lower two LEDs illuminated
Voltage bottom	LED illuminated

Running Frequency

The frequency your pump is currently running at.

Set Frequency

The frequency your pump wants to run at. RPS systems run at 60HZ when there is sufficient solar power.

Bus Voltage

Intermediate voltage value after coming from the grid/generator or solar input and before conversion to three phase AC output.

Output Voltage

The voltage across the pump leads.

Output Current

The current available to the pump.

Pump RPM

The speed the pump is currently rotating.





HOW YOUR PRESSURE SWITCH WORKS

If using a pressure switch in your system, a “Reverse Action” type pressure switch is required. A reverse action pressure switch operates in the opposite manner of a standard pressure switch to accommodate the tank full inputs of the controller. The contacts are open to turn on the pump and closed when pressure is reached and the pump is turned off.

Unscrew the nut on the top of the pressure switch and remove the cover to see the contacts and wire terminals. On the underside of the pressure switch is a 1/8” female NPT inlet that will connect to your plumbing to sense pressure in the system. When the pressure changes the terminals open and the circuit closes.

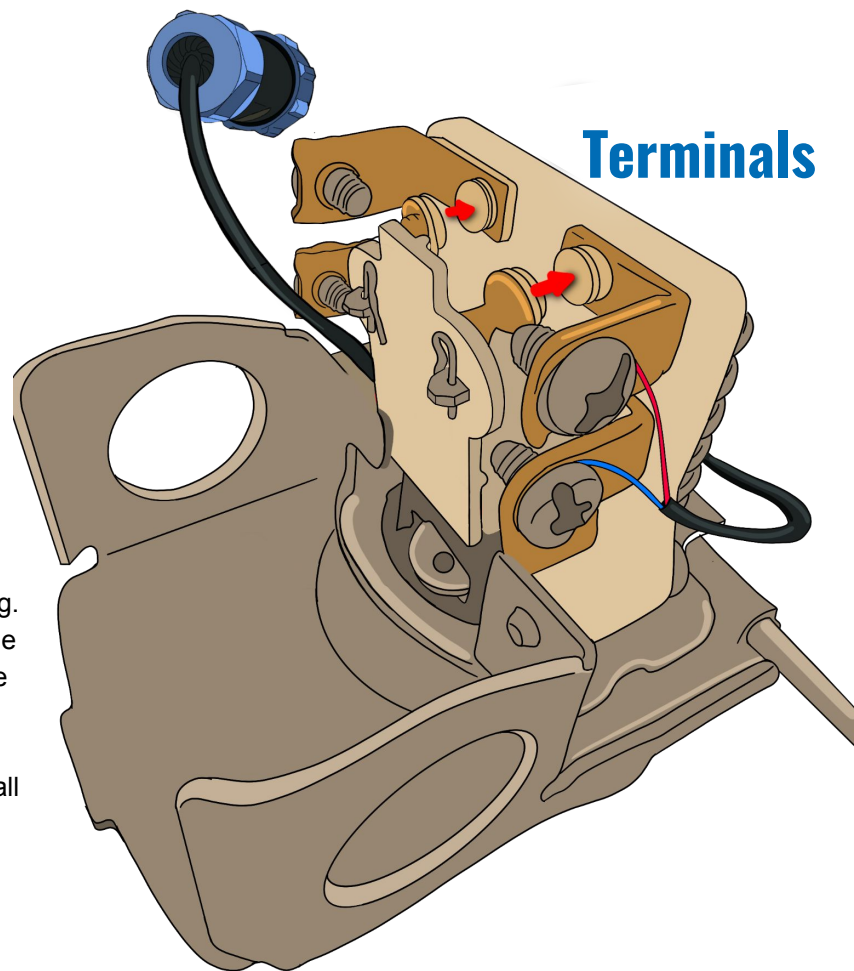
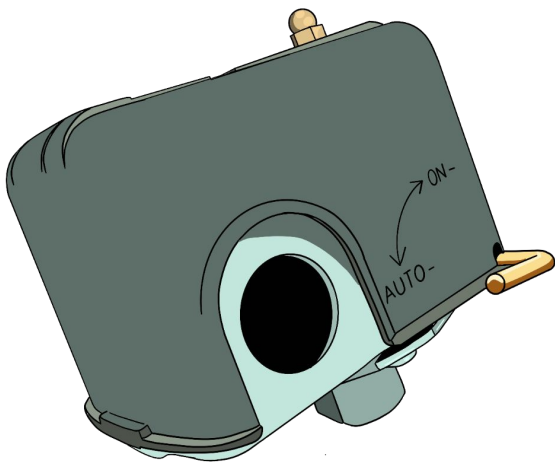

Install

To install a pressure switch:

- Connect the input of the switch to the plumbing. This can be achieved with various fittings at the well head or a tee plus barbs into the poly pipe coming from your pump and going to your intended destination.
- Unscrew the cover of the switch using the small nut on the top of the assembly.
- Take the red and blue wires from your sensor pigtail and extend them using outdoor rated wire and the provided small splice kit.
- Connect the wire to either of the terminals, **ensuring they are on the same side** of the switch, and then connect your pigtail to the input on your Pro Series Controller.
- **Polarity of these wires does not matter. (either wire can be connected to either terminal as long as they are on the same side.)**

OPEN = PUMP ON

CLOSED = PUMP OFF



WINTERIZING / FREEZE PROTECTION

RPS pumps are built to run year-round. However, if you only need to use your well pump during certain seasons, you may want to 'winterize' the system. To do this, simply switch the controller to OFF. If you have an adjustable mount, tilt the panels to achieve a steeper angle so snow doesn't collect on the panels. If you have a check valve, be sure to drain out the water in your above-ground pipe or add a "weep hole" which is a small hole in your drop pipe down in the well, so the water in the line above can slowly drain back down the casing.

Most often, it's possible to leave the pump in the well for the winter; the exception is if your water level and pump are close to the surface and are susceptible to freezing. If you do remove your pump from the well for the winter, leave it completely submerged in non-freezing water.

To start the system back up in spring, just turn it on! The pump will not be damaged by periods of non-use as long as the pump remains submerged in water. Care must be taken to prevent water on either side (outlet or inlet) of the pump from freezing.

You can protect your plumbing from freezing in a few different ways:

- Use a pitless adapter to bring the drop pipe out the side of the well casing to keep all plumbing lines below the frost line for your area.
- Use a weep hole in the drop pipe to allow the water above to drain back into the well when the sun goes down and the pump is no longer pumping.

Surface pumps must be kept in an area that will not freeze as frozen pipes on the inlet or outlet side can damage your pump by causing it to deadhead or run dry. Also freezing water within the pumping chamber can expand and damage your impellers or crack the metal housing.





SYSTEM WARRANTY



Rural Power Systems Inc. (RPS Inc.) extends to the original consumer purchaser a limited warranty against defects in material and workmanship for a period of twenty-four months from the date of purchase. RPS Inc. will repair or replace any defective part or parts of the product free of charge within the first twenty-four months of purchase.

RPS Inc. offers an easy-to-install Do-It-Yourself (DIY) kit intended for the consumer to install themselves or with the help of friends or family. In some cases, the customer may decide to hire a professional to complete some or all of the installation. Whether self-installed or professionally installed, RPS Inc. is unable to offer any compensation for troubleshooting, replacing parts, pulling pumps or anything else involved in the troubleshooting/replacement process, regardless of the reason for the warranty claim. But never fear, RPS Inc. has tens of thousands of customers across the USA who have successfully installed and, in those rare cases, were able to troubleshoot their system with the help of RPS Inc. support engineers!



In the event of a malfunction, the purchaser must return the product to receive a replacement. The warranty is limited to the repair or replacement of the product purchases from RPS Inc. RPS Inc. disclaims all liability for indirect and/or consequential damages, such as any installation charges, damage to mounting structures/buildings or loss of revenue.

The warranty does not apply when the equipment has not been installed according to the instructions or damage has occurred through abuse, carelessness, improper installation, accident of mishandling during shipment, or connecting to an improper voltage (most commonly, connecting too many panels in series for your controller). Your warranty is linked to your product's serial number, which is on record at RPS Inc. RPS Inc. will quote all replacements not covered by warranty or outside the warranty period.



TESTING/ TROUBLESHOOTING

TEST 1 — CHECK SOLAR PANELS. May need solar panel adjustment. Refer to 'Tilt Angles' in the manual for your season and latitude. Is there cloud cover? Is it late or early in the day? Is there even a small amount of shade on the panels? Adjust panels to be in full sun and free from shade, and/or check back when there is more sunlight.

TEST 2 — HARD RESET. Turn off DC disconnect, Power Down Generator, if applicable. Leave disconnected until LEDs on front cover power down then re-energize the system (min 60 sec).

TEST 3 — READ RUNTIME PARAMETERS HZ TEST. Plug in keyboard, press hit SHIFT key to cycle to the Hz, Voltage, and RPM setting. Ideally between 40 and 60hz. We can increase the minimum value but on solar it is usually as high as it can be with the power available.

TEST 4 — PUMP WIRES. Set your multimeter to Ohms (resistance) and measure the resistance between each pump wire (1 to 2, 2 to 3, 1 to 3) They should be roughly the same and all should test open when referencing Ground(4 to 1,2,3)

TEST 5 — SOLAR INPUT VOLTAGE. Set your multimeter to VDC Test before DC cutoff switch and after, should have 100+ volts DC, Under 400 VDC.

TEST 6 — AC INPUT VOLTAGE. Set your multimeter to VAC AC input should be 220v to 240v AC single phase.

TEST 7 — CURRENT TO PUMP. Plug in keyboard, hit SHIFT key to cycle to the A setting. Reading should be at least 4 Amps. Optionally, use the clamp on an ammeter around a single pump wire.

TEST 8 — SOLAR PANEL VOLTAGE. If your solar panel voltage is insufficient to power the controller then we need to identify the weak or bad electrical connection. Disconnect your MC4 panel wires and begin by testing the open circuit voltage of a single panel by inserting the leads into the MC4 connectors and reading the voltage. Repeat with the next panel continuing to build voltage until the faulty connection or panel causes the voltage to drop.

TEST 9 — SENSOR WIRING. If you are reading a tank full alarm but your level/ pressure is low first remove the sensor input. If the condition resolves this indicates a short in the wire run or has the wrong wires connected. Set your multimeter to Ohms (resistance) and measure the resistance on pins 1 and 3 on the sensor plug. Lift and drop the float to observe resistance changes.

TEST 10 — REVERSE PUMP WIRING. We always size the pump to provide water over the average pump end value. If your pump is spinning at 60Hz and starting normally but you are not getting water it could indicate the pump is spinning backwards. Swap the first two wires going into terminals 1 and 2 of the pump connector to reverse pump direction. If this does not correct the problem return the wires to the order specified in the manual on page 4.





TROUBLESHOOTING FLOWCHART

If you run into issues with your RPS Pro system don't worry! Our engineers are available to take your call and help you get water moving.

Before you get one on the phone there are some tests and checks you can do to find the root cause or obtain information the engineer may ask you to get started.

This may help you solve your issue or speed up the troubleshooting process with the engineer.

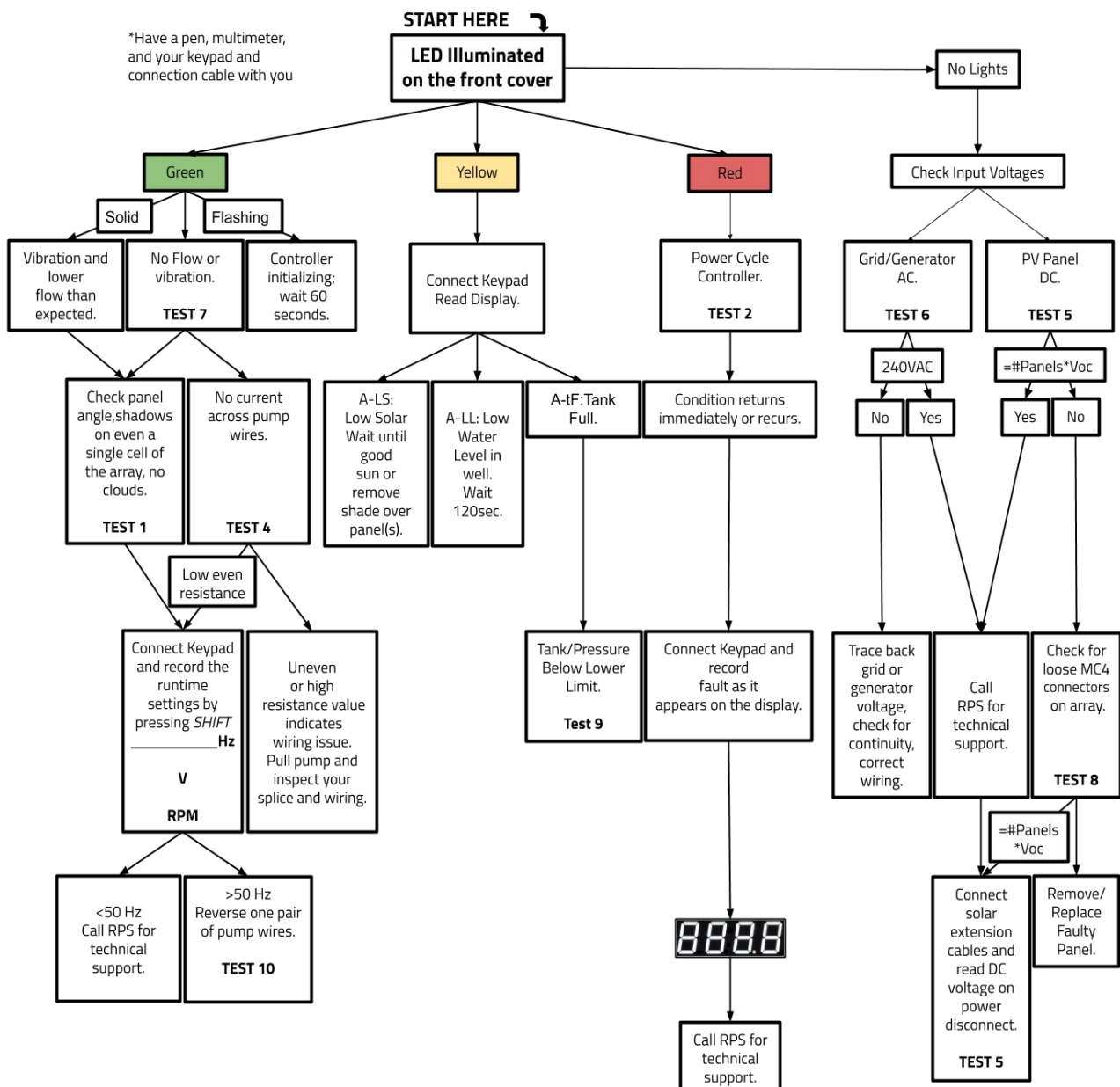



ADDITIONAL SUPPORT

Need additional help getting your system running? We're here to help!

If you're having issues getting your system pumping we have videos on each section of the setup, including a FULL pro-series install link at RPSsolarpumps.com/pro



For detailed videos on troubleshooting and a digital user manual you can share, please visit:
RPSsolarpumps.com/pro



NEW
*Text our
Engineers!*

youtube.com/rpssolarpumps

We're committed to making sure you get water. Our Engineers are standing by to help with any issues.

Call or **TEXT** (questions, notes, observations & photos encouraged!)

530-240-3825

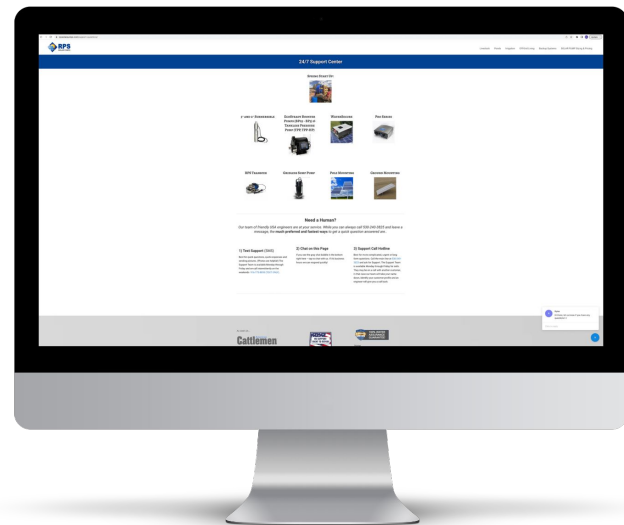

NOTES

NOTES





RPS Solar Pumps
40250 County Rd 27
Woodland, CA, 95776

530.240.3825
Call or Text